

NMOP-10166

Touch Sensor with ARGB LED

Features:

Touch sensing function

- At low power mode typical 10.5uA@5V
- Sensitivity can adjust by the capacitance outside
- Auto calibration for life
- Stable touching detection with isolation object cover the component

Addressable RGB LED function

- Support control circuit to be integrated with RGB chips into a single package
- Support signal reshaping to pass control waveforms to next adjacent driver
- 256-step gray-scale output to allow 16,777,216-color display
- Constant current PWM control

Package feature

- Component with touching detection and ARGB LED function
- ROHS Compliant. Halogen & Pb free.
- Operating voltage 3.3V~5.5V

Typical Applications :

- Consumer product, Gaming, Toys
- Computer peripheral products
- Home appliances
- Button key replacement

Package Dimensions

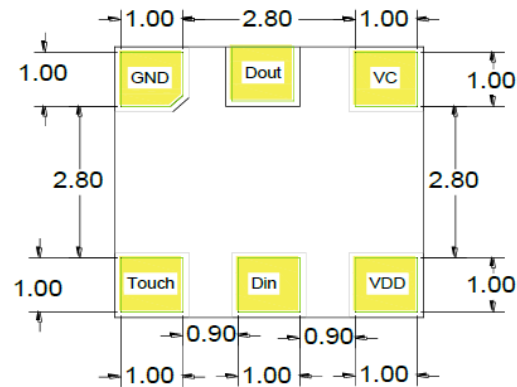
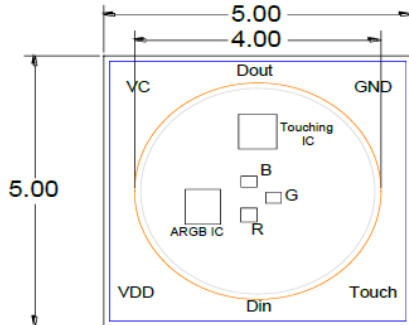

NO.	Symbol	Function Description
1	Touch	Touch sensing signal output
2	GND	Ground
3	VDD	DC power input
4	Din	Control date signal input
5	Dout	Control date signal output
6	VC	Capacitor sampling pin

Note : 1.All dimension are in millimeter tolerance is ± 0.1 mm unless otherwise noted.
2.Specifications are subject to change without notice.

Recommended Soldering Pad Dimensions

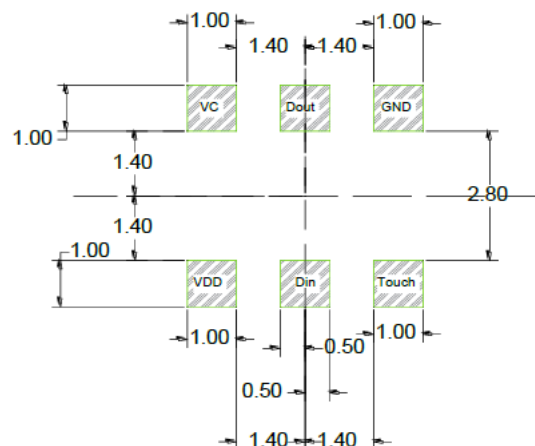

Note:1.The tolerance unless mentioned is ± 0.1 mm,unit=mm.

Application Circuit

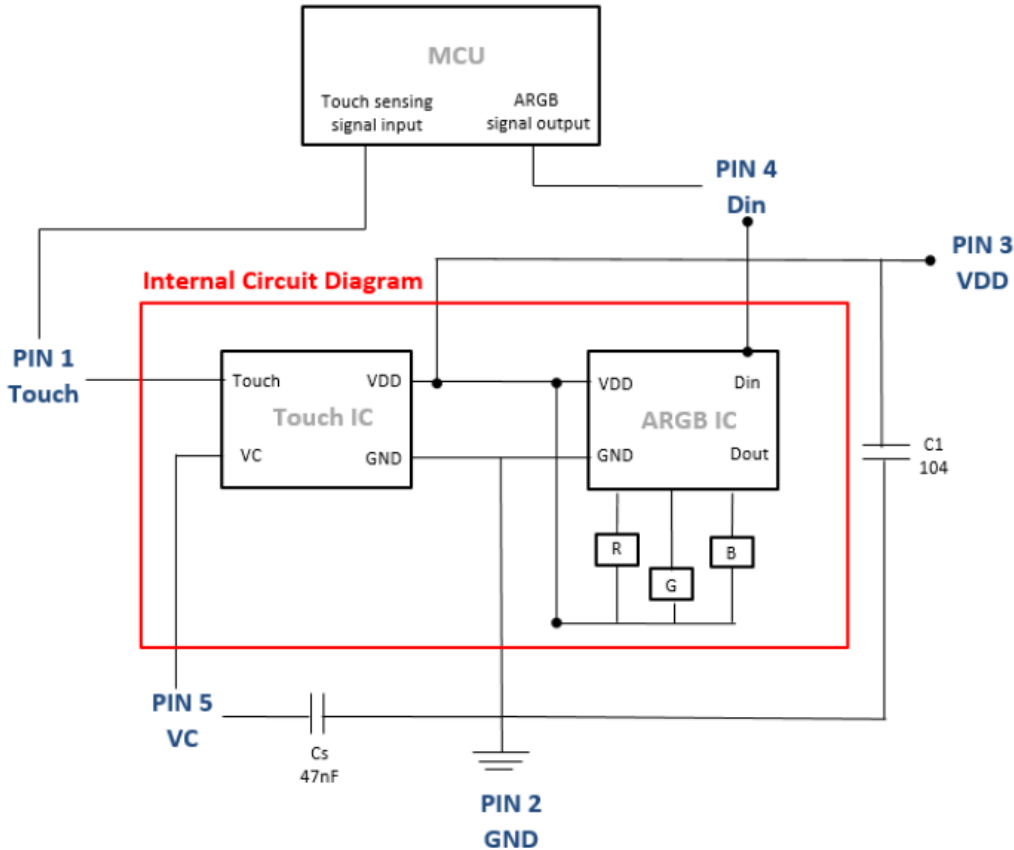

Application Note:

1. Initial Pin 1(Touch) output is 0(Low level) as power on. When touching sensor detect a touch, Pin 1(Touch) switch to 1(High level). When the touching sensing is removed. It will switch Pin 1(Touch) from 1(High level) to 0 (Low level).
2. When Pin5 (VC) is Adding the Cs(47nF) to VSS, the sensitivity is most sensitive. When reduce the values of Cs .It will reduce sensitivity in the useful range. ($1\text{nF} \leq C_s \leq 47\text{nF}$).
3. The material of panel covering on the PCB cannot include the metal or the electric element. The paints on the surfaces are the same. The cover's thickness design rule is under 2mm.
4. The power supply must be stable. If the supply voltage drift or shift quickly, maybe causing sensitivity anomalies or false detections.
5. The sensitivity adjustment capacitors (Cs) must use smaller temperature coefficient and more stable capacitors. Such are X7R, NPO for example. So for touch application, recommend to use NPO capacitor, for reducing that the temperature varies to affect sensitivity.

Absolute Maximum Ratings

(Ta=25°C)

Parameter	Symbol	Ratings	UNIT
Operating Temperature	T _{opr}	-25 ~ +85	°C
Storage Temperature	T _{stg}	-30 ~ +100	°C
Supply Voltage	VDD	3.3 ~ 5.5	V

Typical Electrical & Optical Characteristics

(Ta=25° C)

Parameter		Symbol	Condition	Min.	Typ.	Max.	Unit	
Touch sensing IC	Supply Voltage	VDD	----	3.3	5	5.5	V	
	Standby Current	IOPL	VDD=5V, no load	----	10.5	----	uA	
	High Level Input Voltage	VIH	VDD	2/3	----	----	VDD	
	Low Level Input Voltage	VIL	VDD	----	----	1/3	VDD	
	Output Response Time	TR	VDD=5V	----	48	----	ms	
ARGB IC	Supply Voltage	VDD	----	3.3	5	5.5	V	
	Each R/G/B Current	IOL	VDD=5V	----	12	----	mA	
	Input High Voltage	VIH	----	2.7	----	VDD	V	
	Input Low Voltage	VIL	----	0	----	1	V	
LED	Luminous Intensity	IV	R	VDD=5V	----	320	----	mcd
			G		----	700	----	
			B		----	150	----	
	Dominant Wavelength	λd	R	VDD=5V	----	622	----	nm
			G		----	525	----	
			B		----	468	----	
	Viewing Angle	2θ1/2	VDD=5V	----	120	----	deg	

Touch sensing Time chart Description

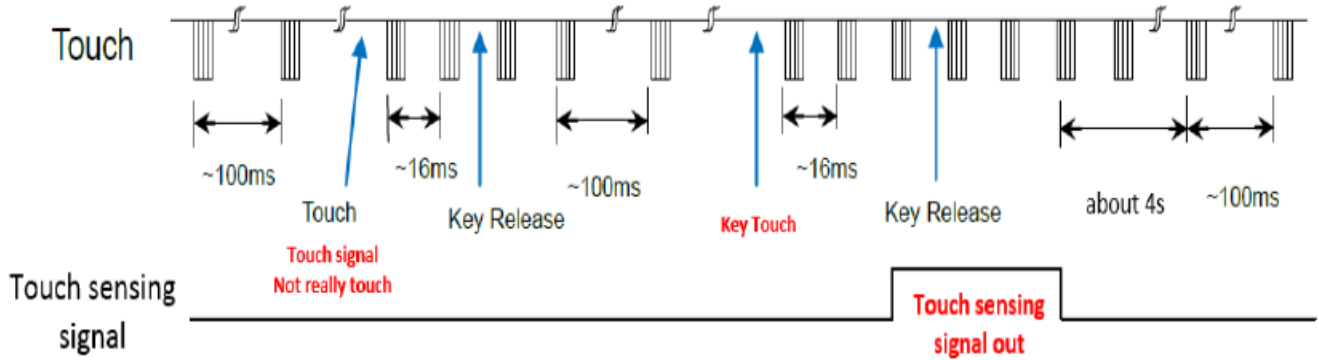

ARGB LED Functional Description Timing Wave Form

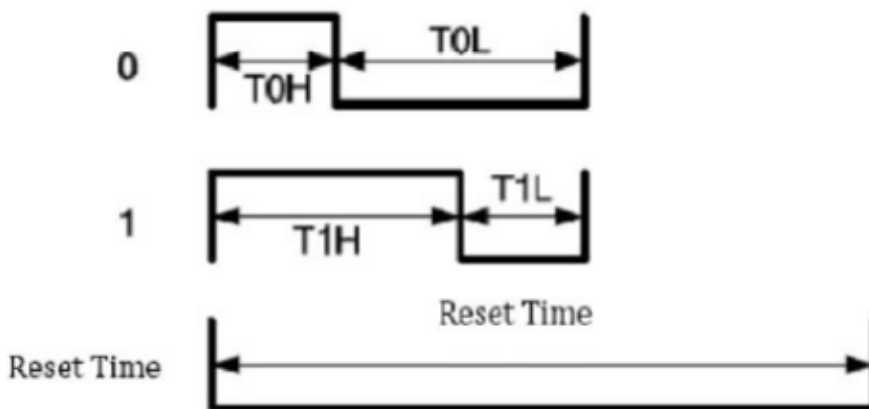

Item	Description	min	Typical	Allowance	unit
T0H	0 code, High-level time		0.3	±0.15	us
T0L	0 code, Low-level time		0.9	±0.15	us
T1H	1 code, High-level time		0.9	±0.15	us
T1L	1 code, Low-level time		0.3	±0.15	us
Trst	Reset code, Low-level time	250			us

Single Data in 24bit for RGB

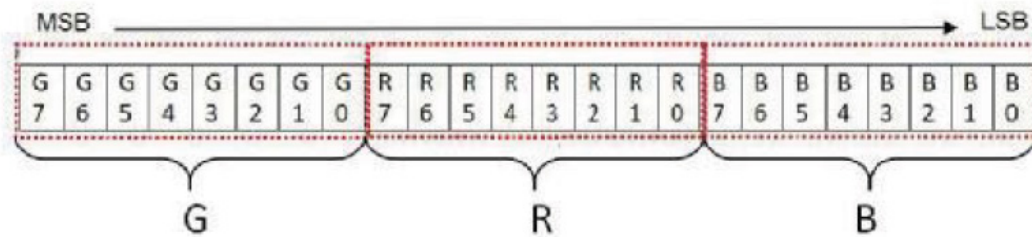

Advance Function Mode

This product has a Advance Function mode that supports the MCU to start with a specific command setting. Advance Function Mode includes the following function

1. Feedback the cascaded number of LEDs and maximum sink current of R/G/B channel
2. Current Gain control:32 level(5bits) to adjust maximum sink current of R/G/B channel
3. Programmable PWM refresh rate (1.25kHz/2.5kHz/5kHz/10kHz)

Typical Electro-Optical Characteristics Curve

