

# NMOP-10136

## LED SMD

### Features:

1. Meet RoHS.
2. Full Color SMD Chip LED With IC Control.
3. Top view Package in 12.0mm carrier tape on 7" diameter reel.
4. Each RGB chip is 8 bit control, total of 16M color can be displayed.

### Descriptions:

The NMOP-10136 SMD has wide viewing angle and optimized light coupling by inter reflector, The low current requirement makes this device ideal for portable equipment or any other application where power is at a premium.

### Applications:

1. Consumer product, Home appliances, Telecommunication, light bar.
2. Toy lights, Christmas lights, Decorative lights.

## Device Selection Guide

Part No	Material	Color	
		Emitted	Lens
NMOP-10136	AlGaInP	Red	Water Clear
	InGaN	Blue	
	InGaN	Grren	

## Package Dimensions

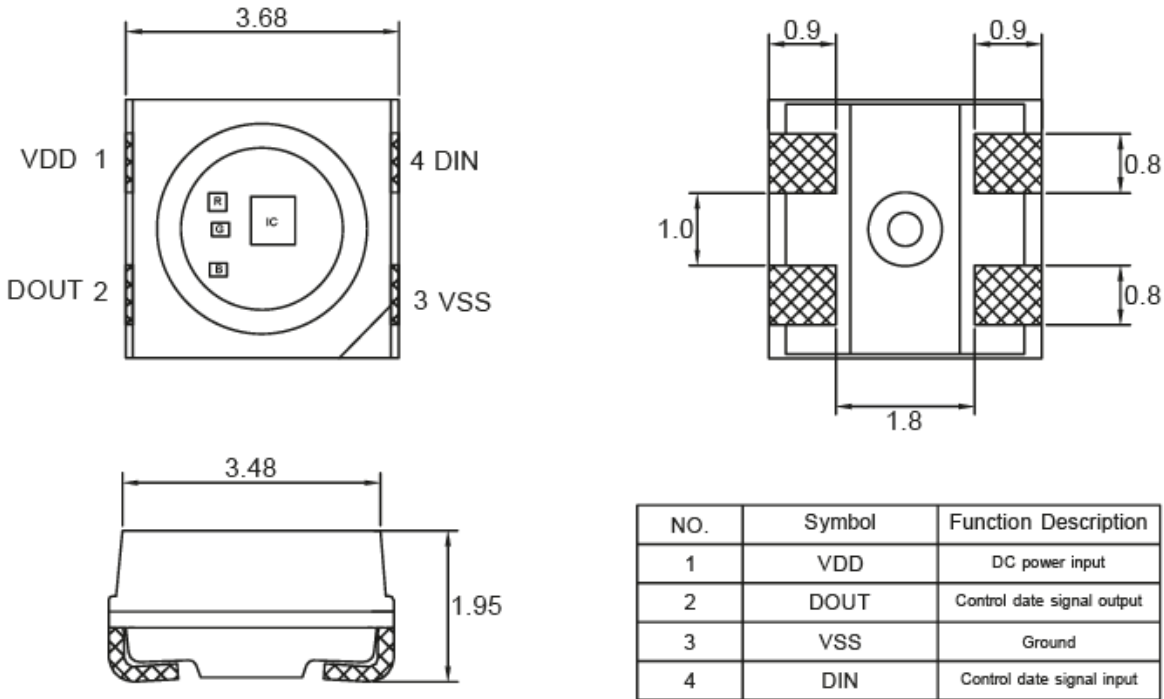

Note : 1. All dimension are in millimeter tolerance is  $\pm 0.2\text{mm}$  unless otherwise noted.  
 2. Specifications are subject to change without notice.

## Recommended Soldering Pad Dimensions

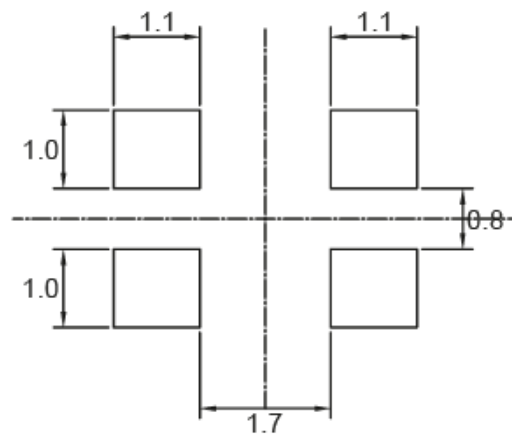

Note : The tolerances unless mentioned is  $\pm 0.1\text{mm}$ , Angle  $\pm 0.5$ . Unit=mm.

## Absolute Maximum Ratings

(Ta=25°C, VDD=5V, VSS=0)

Parameter	Symbol	Ratings	UNIT
Supply Voltage	VDD	-0 ~ +6.0	V
LED Output Current	I <sub>OUT</sub>	20	mA
Operating Temperature	T <sub>opr</sub>	-40 ~ +85	°C
Storage Temperature	T <sub>stg</sub>	-40 ~ +100	°C

## Typical Electrical & Optical Characteristics

(Ta=25° C)

Parameter	Symbol	Min.	Typ.	Max.	Unit	Condition
Supply Voltage	VDD	3.3	5	5.5	V	
Each R/G/B Current	IOL	---	12	---	mA	VDD=5V
Input High Voltage	VIH	2.7		VDD	V	DI,
Input Low Voltage	VIL	0		1.0	V	DI,
Output High Voltage	VOH	4.5				IOH=4mA
Output Low Voltage	VOL			0.4 VDD	V	IOL=4mA
Operation Current	IDD			2	mA	B, G, R no load
Pull Down Resistance	R <sub>PD</sub>		500K		Ω	Din, Dout (VDD=5V)

## Electrical Optical Characteristics

at Ta=25°C

Items	Symbol	Min	Typ.	Max.	Unit	Condition
Luminous Intensity	IV	R	200	---	800	mcd
		G	500	---	1600	
		B	80	---	500	
Dominant Wavelength	λD	R	614	---	630	nm
		G	515	---	530	
		B	462	---	478	
Viewing Angle	2θ1/2		120		deg	VDD=5.0V

- 1.The luminous intensity data did not including ±15% testing tolerance.
- 2.The dominant wavelength data did not including ±1nm testing tolerance

## Timing Wave Form

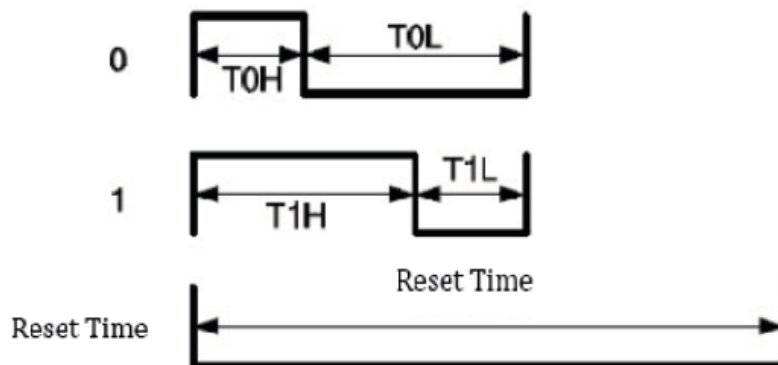

## High Speed mode

Items	Description	Min	Typical	Allowance	unit
T0H	0 code, High-level time		0.3	±0.15	us
T0L	0 code, Low-level time		0.9	±0.15	us
T1H	1 code, High-level time		0.9	±0.15	us
T1L	1 code, Low-level time		0.3	±0.15	us
Trst	Reset code, Low-level time	250			us

## Control Commands for multiple strips connected parallelly

NMOP-10136 supports the scenarios of controlling multiple strips with parallel connection (up to 15 strips). With appropriate commands, each of the strips can be identified and assigned a unique strip dynamic ID (by set dynamic ID command). After the commands is completed, MCU host can individually control and send the display data to each strip with the help of "Clean ID" "Check ID" "specify ID" commands.

### Single Data in 24bit for RGB

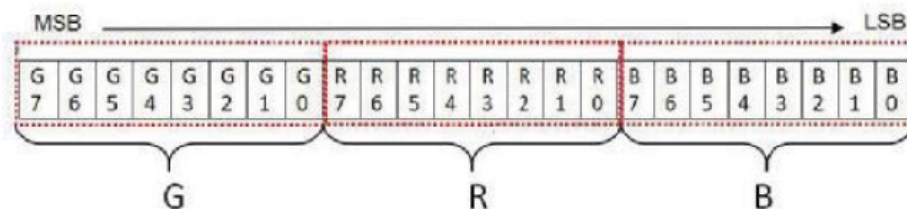

#### Advance Function Mode

This product has a Advance Function mode that supports the MCU to start with a specific command setting.

Advance Function Mode includes the following function.

1. Feedback the cascaded number of LEDs and maximum sink current of R/G/B channel
2. Current Gain control:32 level(5bits) to adjust maximum sink current of R/G/B channel
3. Programmable PWM refresh rate (1.25kHz/2.5kHz/5kHz/10kHz)

## Carrier Type Dimensions

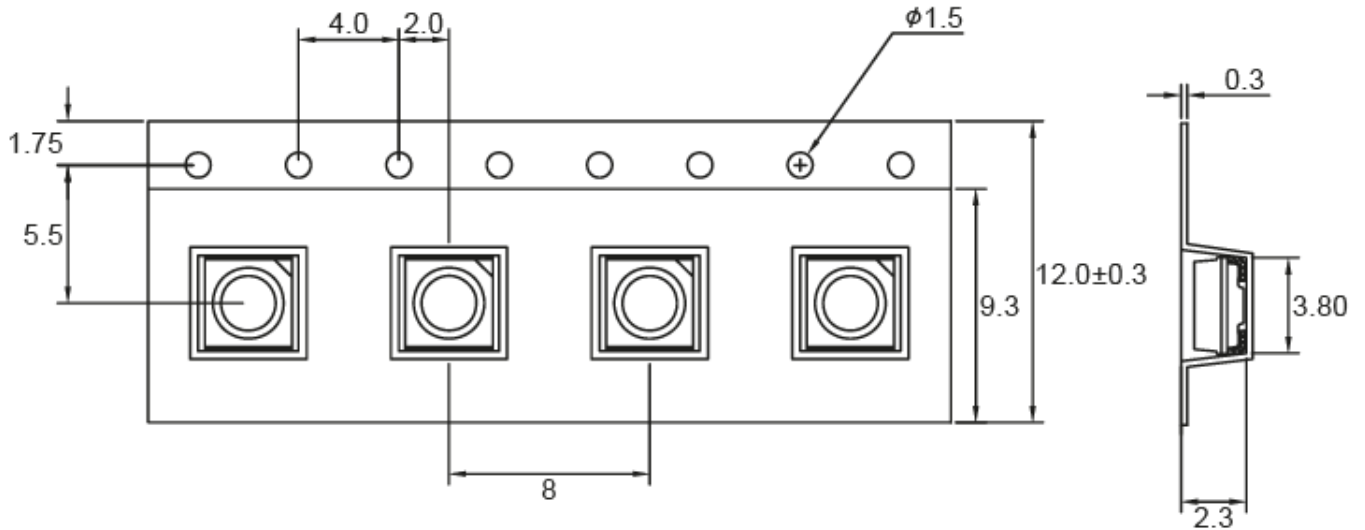

Note : The tolerances unless mentioned is  $\pm 0.1$ mm, Angle  $\pm 0.5$ . Unit=mm.

## Packing Specifications

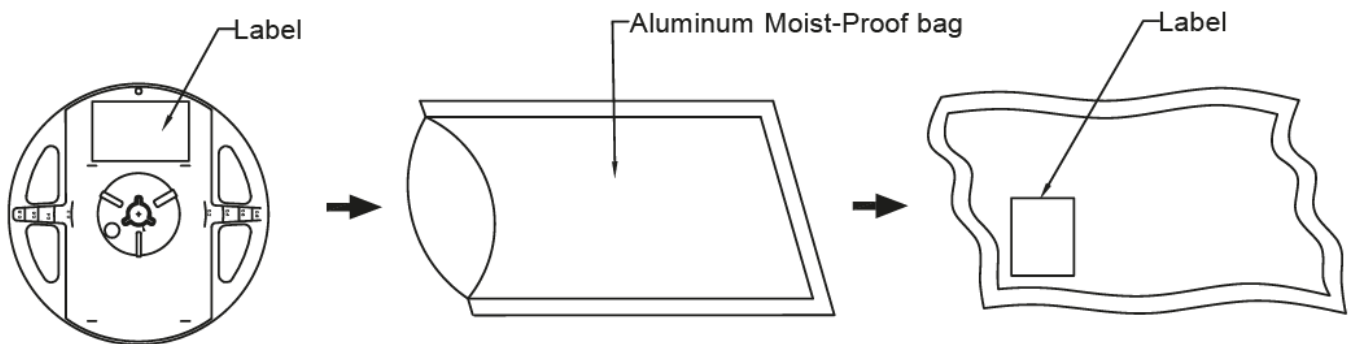

Part No.	Description	Quantity/Reel
NMOP-10136	12.0mm tape, 7" reel	500 PCS

NMOP-10136

## Label Explanation



**N Neumüller**  
Elektronik GmbH  
www.neumueller.com

Typ / Part No. \_\_\_\_\_  
Date Code / Rank \_\_\_\_\_  
Menge / Quantity \_\_\_\_\_  
Kunde / Customer \_\_\_\_\_

BIN : Luminous Intensity

## Reel Dimensions

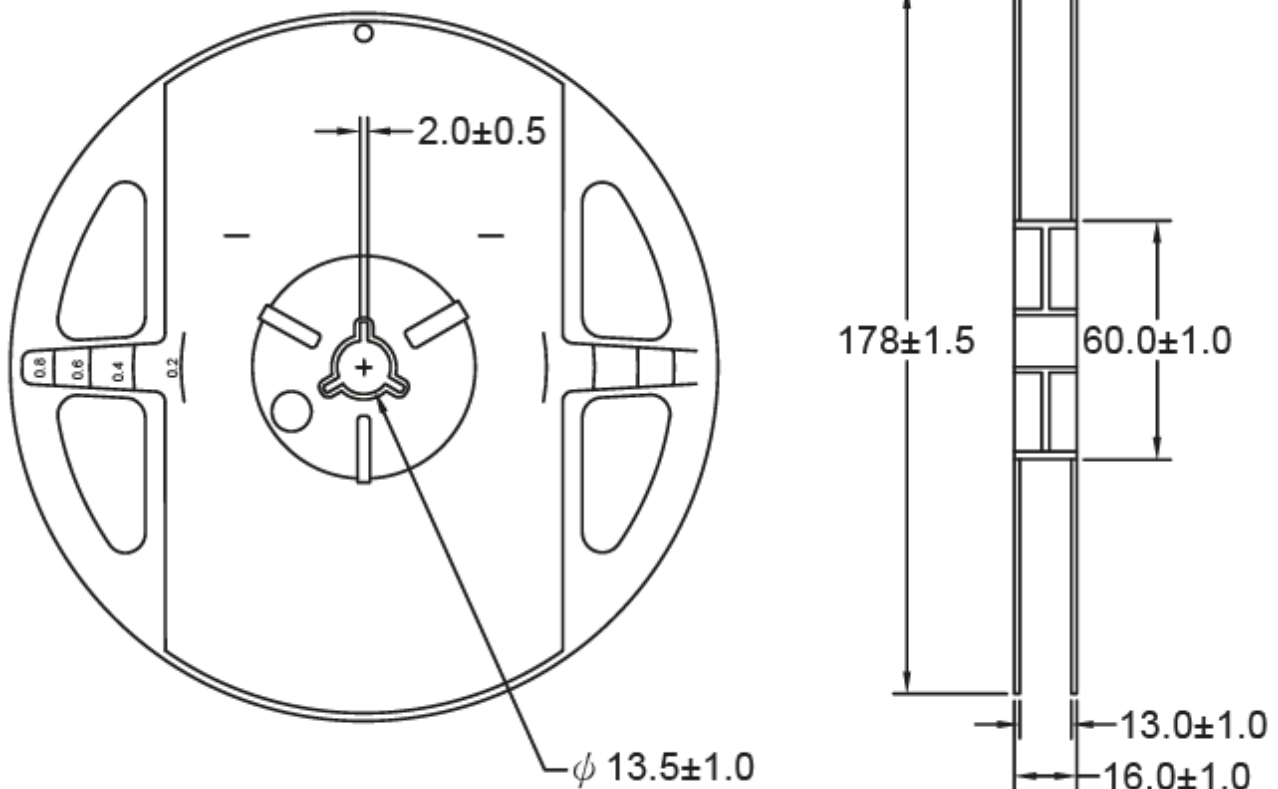

**NMOP-10136**

## Box Explanation

1. 5 BAG / INNER BOX
2. INNER BOX SIZE : L X W X H 23cm X 8.5cm x 26cm

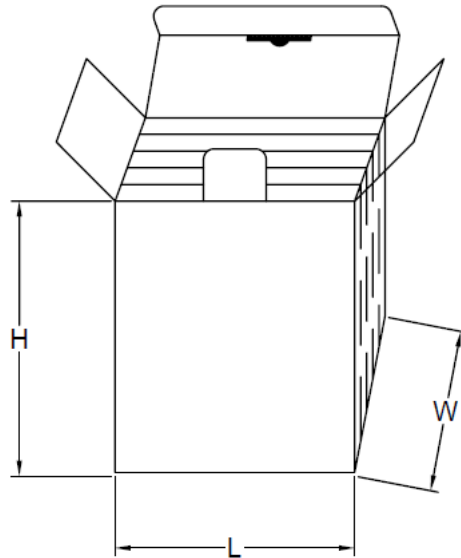

3. 10 INNER BOXES / CARTON
4. CARTON SIZE : L X W X H 58cm X 34cm x 35cm

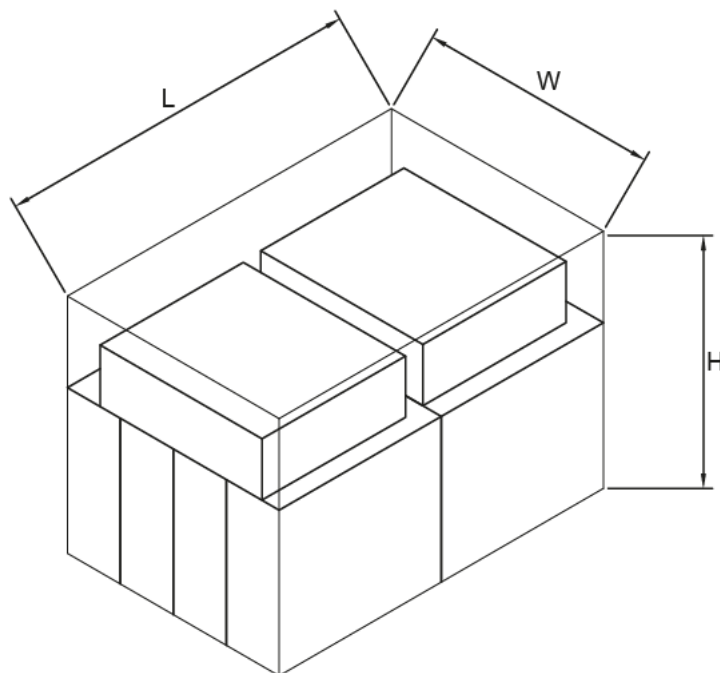



## Recommended Soldering Conditions

### 1. Hand Solder

Basic spec is 280°C 3 sec one time only.

### 2. PB-Free Reflow Solder

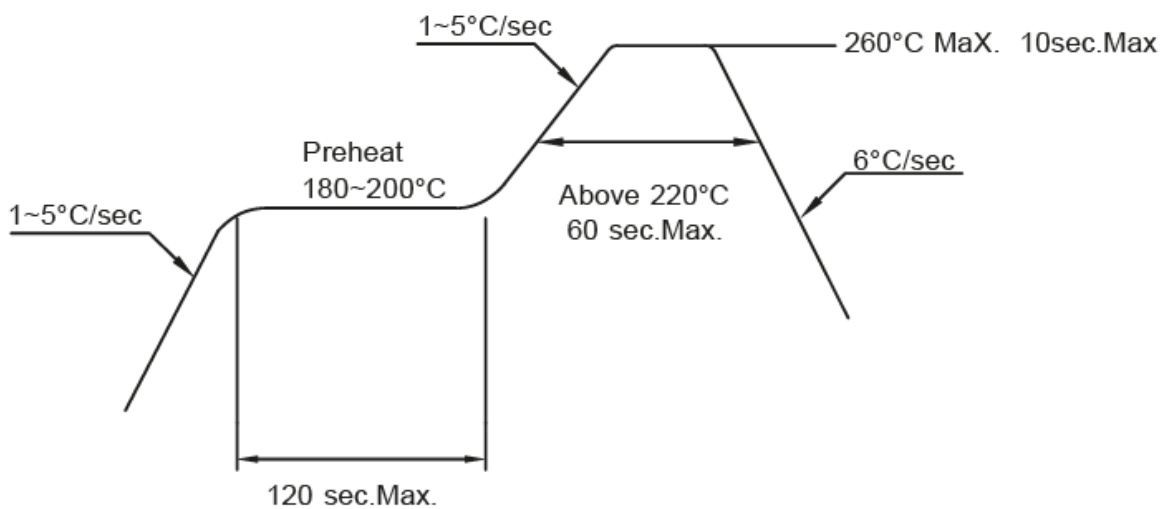

- Note:
- 1.Reflow soldering should not be done more than two times.
  - 2.When soldering,do not put stress on the LEDs during heating.
  - 3.After soldering,do not warp the circuit board.

## Precautions For Use:

### Storage time:

1. Calculated shelf life before opening is 12 months at  $< 30^{\circ}\text{C}$  and  $< 90\%$  relative humidity (RH)
2. After bag is opened, devices which will be subjected to reflow soldering or other high temperature processes must be
  - a) Assembled within 168 hours in an environment of  $\leq 30^{\circ}\text{C}$  / 60% RH, or
  - b) Stored at ambient of 10% RH or less
3. Devices are required baking before assembly if:
  - a) Humidity Indicator Card reads  $>10\%$  (for level 2a -5a) or  $>60\%$  (for level 2) at ambient temperature  $23\pm 5^{\circ}\text{C}$
  - b) 2.a) or 2.b) doesn't meet
4. If baking is required, devices should be baked for  $>24$  hours at  $60\pm 5^{\circ}\text{C}$  / 5% RH. Performing baking only once, and using the baked devices within 8 hours.

## Recommended route

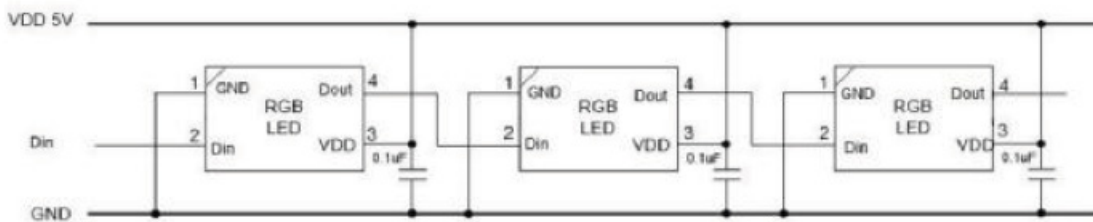

## Cleaning

Use alcohol-based cleaning solvents such as isopropyl alcohol to clean the LED.

## ESD(Electrostatic Discharge):

Static Electricity or power surge will damage the LED. Use of a conductive wrist band or anti-electrostatic glove is recommended when handling these LED. All devices, equipment and machinery must be properly grounded.