

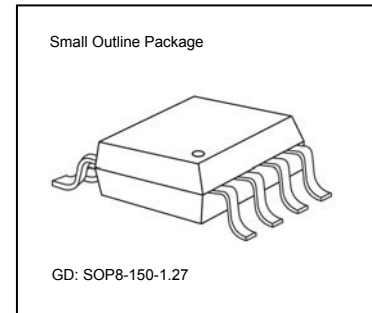

4-Channel All-Ways-On™ Constant Current LED Driver

Features

- Maximum 50V output sustaining voltage
- 4 constant-current output channels
- Constant output current invariant to load voltage change
- Excellent output current accuracy:
between channels: $<\pm 3\%$ (max.), and
between ICs: $<\pm 6\%$ (max.)
- Output current adjusted through an external resistor
- Constant output current range per channel: 10 - 120 mA
- Integrated voltage regulator for 8 - 40 V supply voltage
- Package Type: "Pb-free & Green" package with thermal pad
- Package MSL Level : 3



Current Accuracy		Conditions
Between Channels	Between ICs	
$< \pm 3\%$	$< \pm 6\%$	$I_{OUT} = 10 \sim 120 \text{ mA}$

Product Description

MBI1824 is an instant On/Off LED driver for lighting applications and exploits PrecisionDrive™ technology to enhance its output characteristics. At MBI1824 output stage, 4 regulated current ports are designed to provide uniform and constant current sinks for driving LEDs within a large range of V_F variations.

MBI1824 provides users 4-channel constant current ports to match LEDs with equal current. Users may adjust the output current from 10mA to 120mA through an external resistor, R_{ext} , which gives users flexibility in controlling the light intensity of LEDs. In addition, users can precisely adjust LED brightness from 0% to 100% via output enable (OE) with Pulse Width Modulation.

Additionally, to ensure the system reliability, MBI1824 is built with thermal pad. The thermal pad enhances the power dissipation. As a result, a large amount of current can be handled safely in one package.

Applications

- Automotive lighting
- Channel letter
- Decorative LED lighting

MBI1824 4-Channel All-Ways-On™ Constant Current LED Driver

Typical Application Circuit

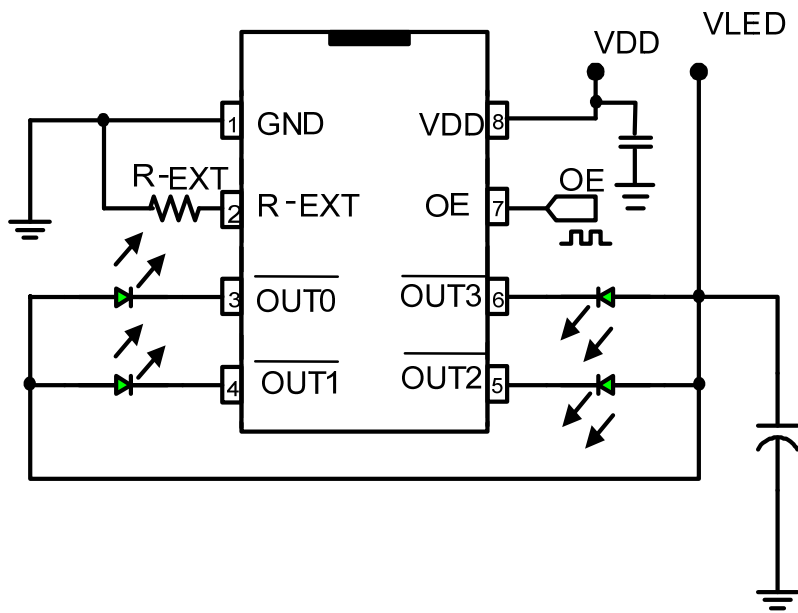

Figure 1

Functional Diagram

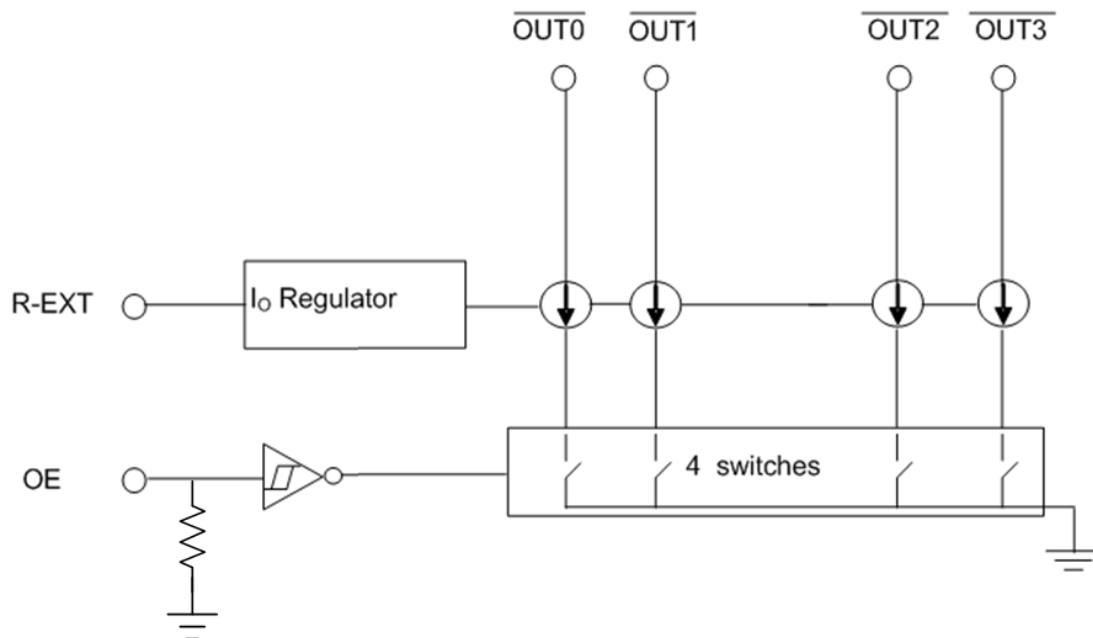
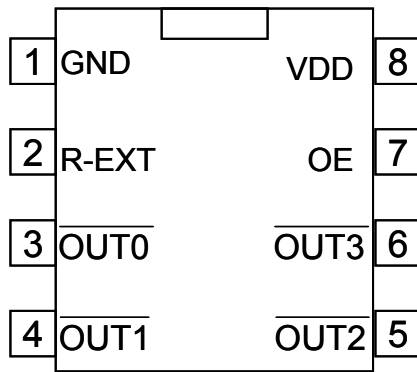

Figure 2

MBI1824 4-Channel All-Ways-On™ Constant Current LED Driver

Pin Configuration



MBI1824GD

Pin Description

Pin Name	Function
VDD	Supply voltage terminal
GND*	Ground terminal for control logic and current sink
$\overline{\text{OUT0}} \sim \overline{\text{OUT3}}$	Constant current output terminals
OE	Output enable terminal When OE is active (High), the output pins are enabled; when OE is inactive (Low), all output pins are turned OFF (blanked).
R-EXT	Terminal used to connect an external resistor (R_{ext}) for setting up output current for all output channels

*To eliminate the noise influence, the thermal pad is suggested to be connected to GND on PCB. In addition, the desired thermal conductivity will be improved, if a heat-conducting copper foil on PCB is soldered with thermal pad.

MBI1824 4-Channel All-Ways-On™ Constant Current LED Driver

Maximum Ratings

Characteristic		Symbol	Rating	Unit
Supply Voltage		V_{DD}	0~40.0	V
Input Voltage		V_{IN}	-0.4~ $V_{DD} + 0.4$	V
Output Current		I_{OUT}	120*	mA
Sustaining Voltage		V_{DS}	-0.5~+50.0	V
GND Terminal Current		I_{GND}	520	mA
Power Dissipation* (On PCB, $T_a=25^{\circ}C$)	GD (SOP 8)	P_D	0.8	W
Thermal Resistance (By simulation)		$R_{th(j-a)}$	33.39	$^{\circ}C/W$
Empirical Thermal Resistance** (On PCB, $T_a=25^{\circ}C$)			125	
Operating Junction Temperature		$T_{j,max}$	125	$^{\circ}C$
Operating Temperature		T_{opr}	-40~+85	$^{\circ}C$
Storage Temperature		T_{stg}	-55~+150	$^{\circ}C$
ESD Rating	Human Body Mode (MIL-STD-883G Method 3015.7)	HBM	Class 2 (2000 ~ 4000V)	-
	Machine Mode (ESDA-STM5.2-1999)	MM	Class 2 (200 ~ 400V)	-

*Users must notice that the power dissipation (almost equaling to $I_{OUT} \times V_{DS}$) should be within the Safe Operation Area shown in Figure 7.

**The PCB size is 4 times larger than that of IC and without extra heat sink.

MBI1824 4-Channel All-Ways-On™ Constant Current LED Driver

Electrical Characteristics

VDD=12V, GND =0 V, Ta=25°C, unless otherwise specified.

Characteristic		Symbol	Condition	Min.	Typ.	Max.	Unit
Supply Voltage		V _{DD}	-	8		40	V
Sustaining Voltage at OUT pin		V _{DS}	$\overline{\text{OUT0}} \sim \overline{\text{OUT3}}$	-	-	50	V
Output Current		I _{OUT}	DC Test Circuit	10	-	120*	mA
Input Voltage	“H” level	V _{IH}	T _a = -40~85°C	2.8	-	V _{DD}	V
	“L” level	V _{IL}	T _a = -40~85°C	GND	-	0.7	V
Output Leakage Current		I _{OH}	V _{OH} = 40.0V	-	-	0.5	µA
Output Current 1		I _{OUT1}	V _{DS} = 0.6V R _{ext} = 2.4kΩ	-	61.5	-	mA
Current Skew 1		dI _{OUT1}	I _{OL} = 30.7mA V _{DS} = 0.6V R _{ext} = 2.4kΩ	-	±1	±3	%
Output Current 2		I _{OUT2}	V _{DS} = 0.8V R _{ext} = 1.3kΩ	-	113.2	-	mA
Current Skew 2		dI _{OUT2}	I _{OL} = 56.7mA V _{DS} = 0.8V R _{ext} = 1.3kΩ	-	±1	±3	%
Regulation of Output Current vs. Sustaining Voltage		%/dV _{DS}	V _{DS} within 1.0V and 3.0V	-	±0.1	-	% / V
Regulation of Output Current vs. Supply Voltage		%/dV _{DD}	V _{DD} within 8.0V and 40V	-	±0.1	-	% / V
Pull-down Resistor of OE		R _{IN(down)}		280	400	520	KΩ
Supply Current	“OFF”	I _{DD(off) 1}	R _{ext} = Open, $\overline{\text{OUT0}} \sim \overline{\text{OUT3}}$ = Off	-	0.57	1	mA
		I _{DD(off) 2}	R _{ext} = 2.4kΩ, $\overline{\text{OUT0}} \sim \overline{\text{OUT3}}$ = Off	-	0.57	1	
		I _{DD(off) 3}	R _{ext} = 1.3kΩ, $\overline{\text{OUT0}} \sim \overline{\text{OUT3}}$ = Off	-	0.57	1	
	“ON”	I _{DD(on) 1}	R _{ext} = 2.4kΩ, $\overline{\text{OUT0}} \sim \overline{\text{OUT3}}$ = On	2.5	3.17	5	
		I _{DD(on) 2}	R _{ext} = 1.3kΩ, $\overline{\text{OUT0}} \sim \overline{\text{OUT3}}$ = On	3.0	3.55	5	
	Standby Current		I _{DD(shdn)}	The OFF time of OE exceeds t _{shdn}	-	0.57	

* Each output current, I_{OUT}, can be driven up to 120mA.

Test Circuit for Electrical Characteristics

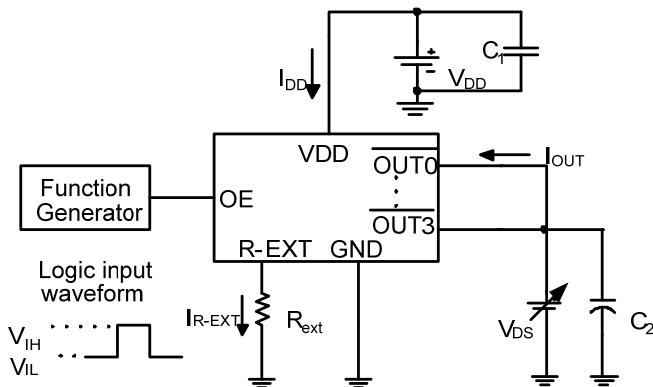

Figure 3

MBI1824 4-Channel All-Ways-On™ Constant Current LED Driver

Switching Characteristics

Characteristic	Symbol	Condition	Min.	Typ.	Max.	Unit
Propagation Delay Time ("L" to "H")	OE - $\overline{\text{OUTn}}$	$V_{DD} = 12.0 \text{ V}$ $V_{DS} = 1.0 \text{ V}$ $V_{IH} = 5 \text{ V}$ $V_{IL} = \text{GND}$ $R_{ext} = 1227 \Omega$ $(I_{OUTn} = 120 \text{ mA})$ $V_L = 4.2 \text{ V}$ $R_L = 26.67 \Omega$ $C_L = 10 \text{ pF}$	-	1.88	2.5	μs
Propagation Delay Time ("H" to "L")	OE - $\overline{\text{OUTn}}$		-	1.3	2.5	μs
Pulse Width	OE		5	-	-	μs
Output Rise Time of $\overline{\text{OUT}}$ (turn off)	t_{or}		-	1.5	2.5	μs
Output Fall Time of $\overline{\text{OUT}}$ (turn on)	t_{of}		-	1.8	2.5	μs
Shutdown Time	t_{shdn}		OE disable time	491	-	825

Test Circuit for Switching Characteristics

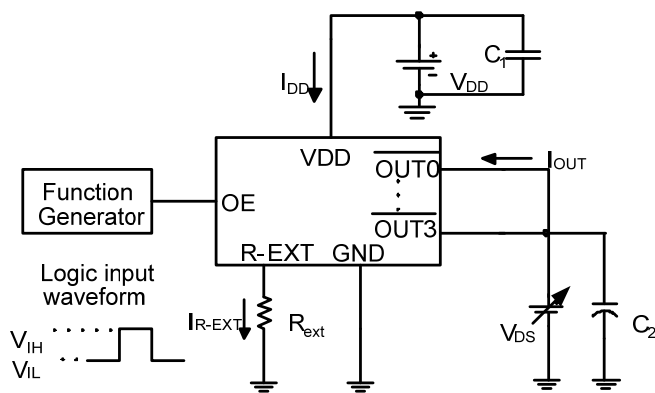

Figure 4

MBI1824 4-Channel All-Ways-On™ Constant Current LED Driver

Constant Current

In LED lighting applications, MBI1824 provides nearly no variation in current from channel to channel and from IC to IC. This can be achieved by:

- 1) The maximum current variation between channels is less than $\pm 3\%$, and that between ICs is less than $\pm 6\%$.
- 2) In addition, the current characteristic of output stage is flat and users can refer to the figure as shown below. The output current can be kept constant regardless of the variations of LED forward voltages (V_F). This guarantees LED to perform the same brightness as user's specification.

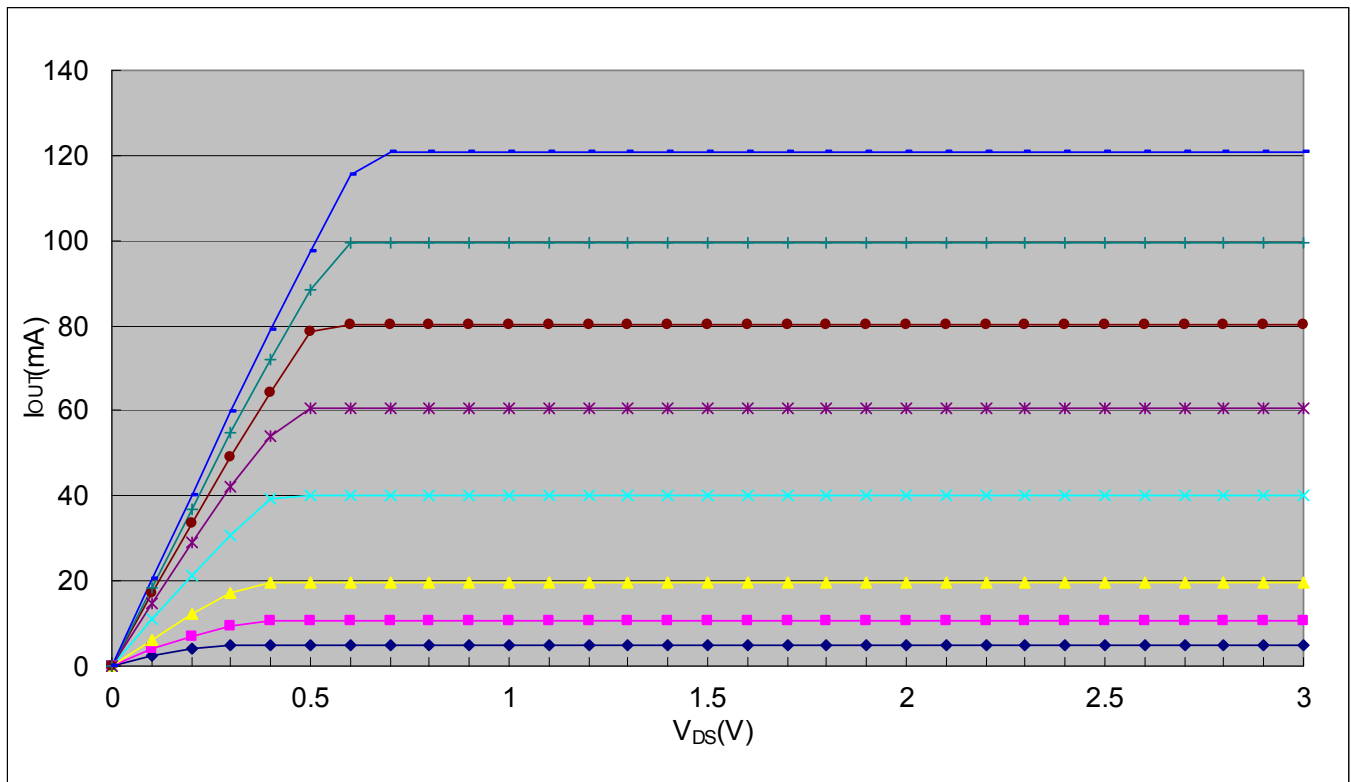

Figure 5

MBI1824 4-Channel All-Ways-On™ Constant Current LED Driver

Setting Output Current

The output current of each channel (I_{OUT}) is set by an external resistor, R_{EXT} . The relationship between I_{OUT} and R_{EXT} is shown in the following figure.

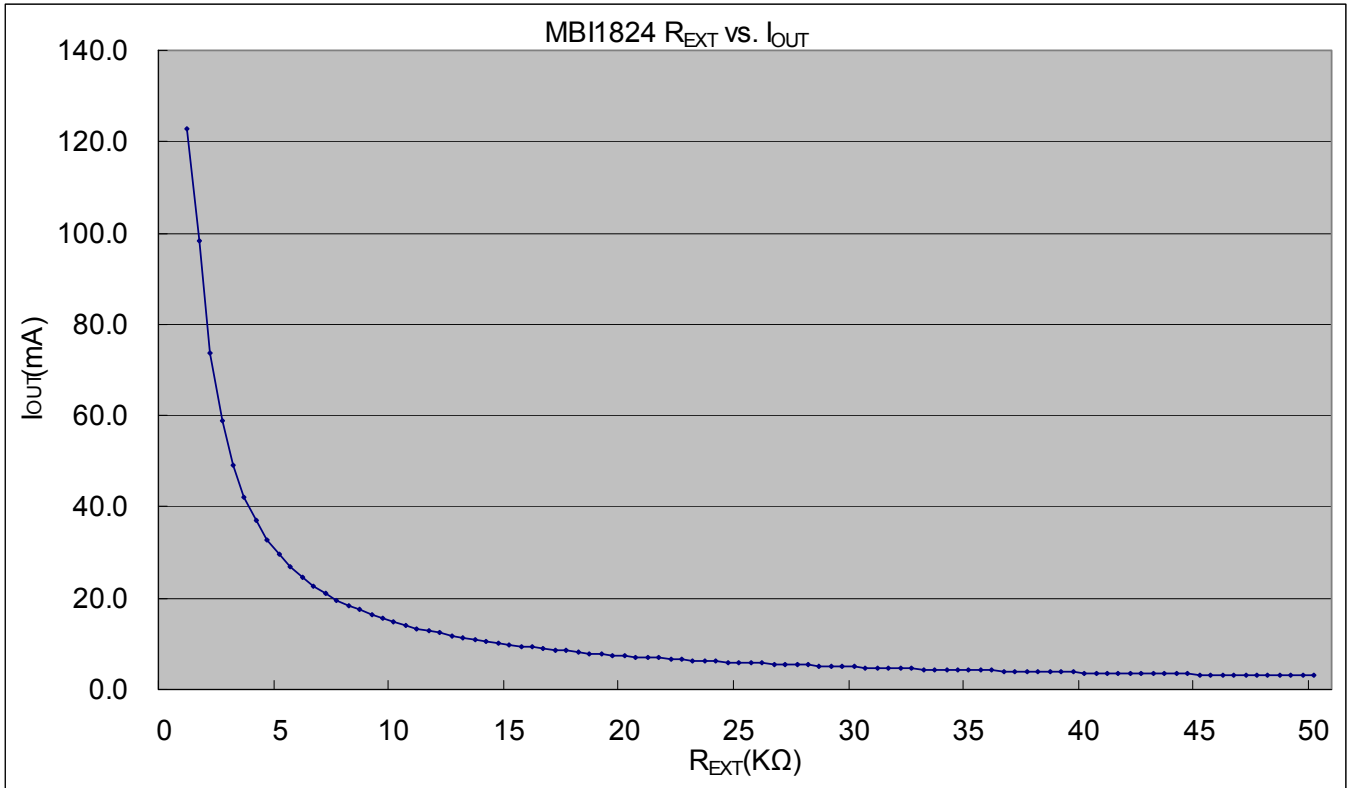

Figure 6

Also, the output current can be calculated from the equation:

$$V_{R-EXT} = 1.23V ;$$

$$R_{ext} = (V_{R-EXT} / I_{OUT}) \times 120 = (1.23V / I_{OUT}) \times 120,$$

$$I_{OUT} = (V_{R-EXT} / R_{ext}) \times 120 = (1.23V / R_{ext}) \times 120 \text{ within } \pm 6\% \text{ chip skew}$$

where R_{ext} is the resistance of the external resistor connected to R-EXT terminal and V_{R-EXT} is the voltage of R-EXT terminal. The magnitude of current (as a function of R_{ext}) is around 113.2mA at 1.3kΩ and 61.5mA at 2.4kΩ.

MBI1824 4-Channel All-Ways-On™ Constant Current LED Driver

Package Power Dissipation (P_D)

The maximum power dissipation, $P_D(\max) = (T_{j,\max} - T_a) / R_{th(j-a)}$, decreases as the ambient temperature increases.

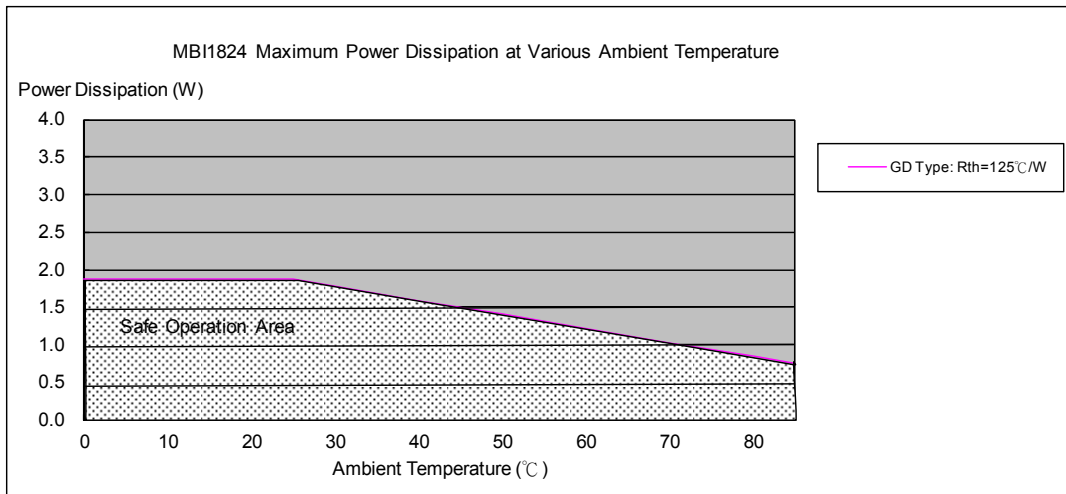

Figure 7

The maximum allowable package power dissipation is determined as $P_D(\max) = (T_{j,\max} - T_a) / R_{th(j-a)}$. When 4 output channels are turned on simultaneously, the actual package power dissipation is $P_D(\text{act}) = (I_{DD} \times V_{DD}) + (I_{OUT} \times \text{Duty} \times V_{DS} \times 4)$. Therefore, to keep $P_D(\text{act}) \leq P_D(\max)$, the allowable maximum output current as a function of duty cycle is:

$$I_{OUT} = \{ [(T_j - T_a) / R_{th(j-a)}] - (I_{DD} \times V_{DD}) \} / V_{DS} / \text{Duty} / 4,$$

where $T_j = 125^\circ\text{C}$;

$$\text{Duty} = t_{ON} / T;$$

t_{ON} : the time of LEDs turning on; T : OE signal period

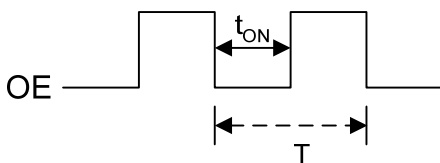

*Note: The empirical thermal resistor $R_{th(j-a)} = 125^\circ\text{C/W}$; it is based on the following structure.

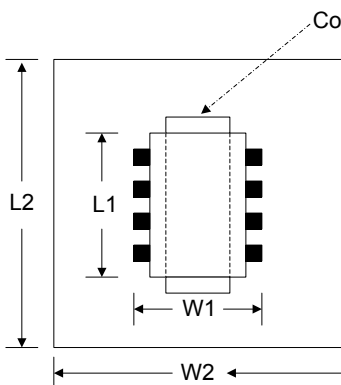

The PCB area $L2 \times W2$ is 4 times of the IC's area $L1 \times W1$.

The thickness of the PCB is 1.6 mm, copper foil 1 Oz. The thermal pad on the IC's bottom has to be mounted on the copper foil.

MBI1824 4-Channel All-Ways-On™ Constant Current LED Driver

Load Supply Voltage (V_{LED})

MBI1824 is designed to operate with adequate V_{DS} to achieve constant current. V_{DS} together with I_{OUT} should not exceed the package power dissipation limit, $P_{D(max)}$.

As in Figure 8, $V_{DS} = V_{LED} - V_F$, and V_{LED} is the load supply voltage. $P_{D(act)}$ will be greater than $P_{D(max)}$, if V_{DS} drops too much voltage on the driver. In this case, it is recommended to use the lowest possible supply voltage or to set an external voltage reducer, V_{DROP} .

A voltage reducer lets $V_{DS} = (V_{LED} - V_F) - V_{DROP}$.

Resistors can be used in the applications as shown in Figure 8.

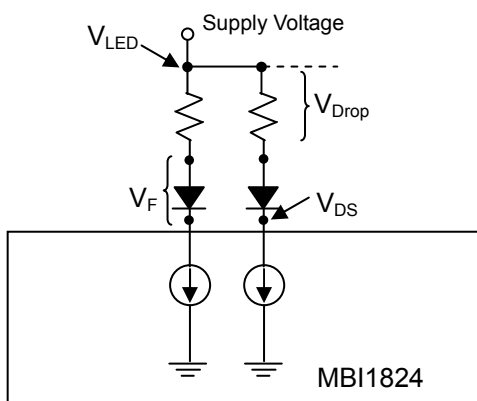

Figure 8

MBI1824 4-Channel All-Ways-On™ Constant Current LED Driver

Soldering Process of "Pb-free & Green" Package Plating*

Macroblock has defined "Pb-Free & Green" to mean semiconductor products that are compatible with the current RoHS requirements and selected 100% pure tin (Sn) to provide forward and backward compatibility with both the current industry-standard SnPb-based soldering processes and higher-temperature Pb-free processes. Pure tin is widely accepted by customers and suppliers of electronic devices in Europe, Asia and the US as the lead-free surface finish of choice to replace tin-lead. Also, it adopts tin/lead (SnPb) solder paste, and please refer to the JEDEC J-STD-020C for the temperature of solder bath. However, in the whole Pb-free soldering processes and materials, 100% pure tin (Sn) will all require from 245 °C to 260 °C for proper soldering on boards, referring to JEDEC J-STD-020C as shown below.

For managing MSL3 Package, it should refer to JEDEC J-STD-020C about floor life management & refer to JEDEC J-STD-033C about re-bake condition while IC's floor life exceeds MSL3 limitation.

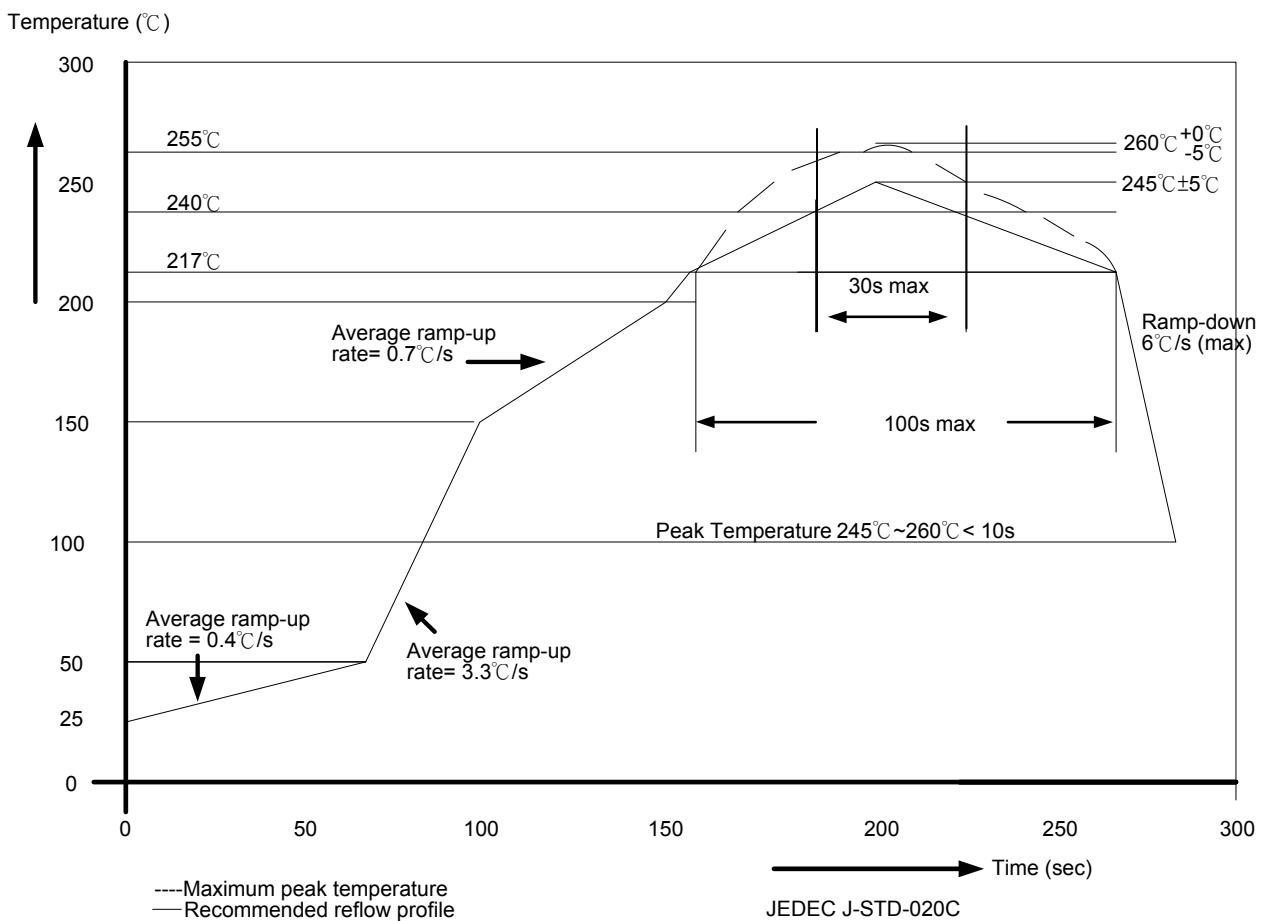

Package Thickness	Volume mm ³ <350	Volume mm ³ 350-2000	Volume mm ³ ≥ 2000
<1.6mm	260 +0 °C	260 +0 °C	260 +0 °C
1.6mm – 2.5mm	260 +0 °C	250 +0 °C	245 +0 °C
≥ 2.5mm	250 +0 °C	245 +0 °C	245 +0 °C

*Note: For details, please refer to Macroblock's "Policy on Pb-free & Green Package".

MBI1824 4-Channel All-Ways-On™ Constant Current LED Driver

Outline Drawing

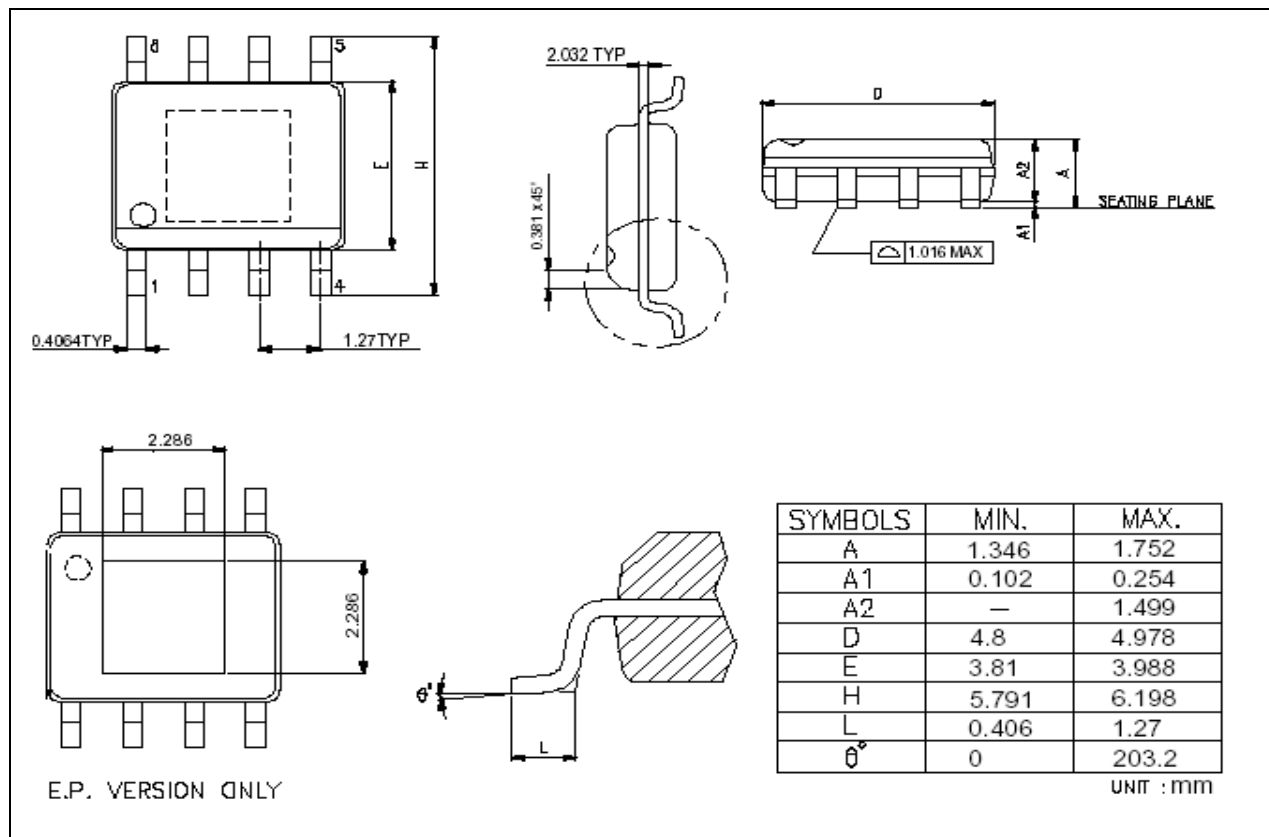

MBI1824GD Outline Drawing

Note: The unit for the outline drawing is mm. Please use the maximum dimensions for the thermal pad layout. To avoid the short circuit risk, the vias or circuit traces shall not pass through the maximum area of thermal pad.

MBI1824 4-Channel All-Ways-On™ Constant Current LED Driver

Product Top-Mark Information

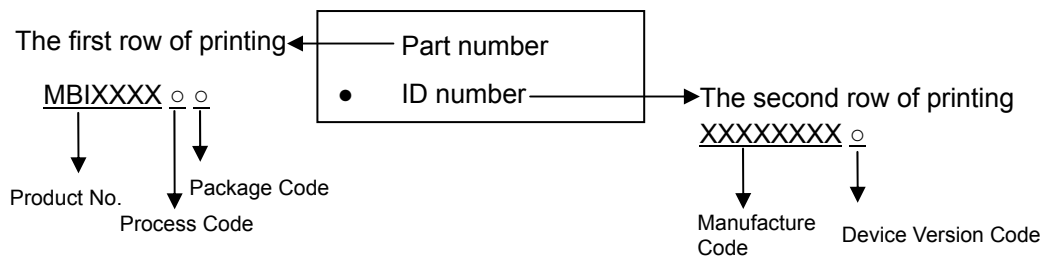

Product Revision History

Datasheet Version	Device Version Code
VA.00	A

Product Ordering Information

Part Number	Package Type	Weight (g)
MBI1824 GD	SOP8-150-1.27	0.079g

*Please place your order with the “**product ordering number**” information on your purchase order (PO).

MBI1824 4-Channel All-Ways-On™ Constant Current LED Driver

Disclaimer

Macroblock reserves the right to make changes, corrections, modifications, and improvements to their products and documents or discontinue any product or service. Customers are advised to consult their sales representative for the latest product information before ordering. All products are sold subject to the terms and conditions supplied at the time of order acknowledgement, including those pertaining to warranty, patent infringement, and limitation of liability.

Macroblock's products are not designed to be used as components in device intended to support or sustain life or in military applications. Use of Macroblock's products in components intended for surgical implant into the body, or other applications in which failure of Macroblock's products could create a situation where personal death or injury may occur, is not authorized without the express written approval of the Managing Director of Macroblock.

Macroblock will not be held liable for any damages or claims resulting from the use of its products in medical and military applications.

All text, images, logos and information contained on this document is the intellectual property of Macroblock.

Unauthorized reproduction, duplication, extraction, use or disclosure of the above mentioned intellectual property will be deemed as infringement.