

General Description

This document presents an overview about the functionality, operating modes, the most important steps, screens and functions of the epc660 Evaluation Kit.

Features

- Fast intro in the epc660 3D-TOF chip
- Many of the epc660 chip operation modes can be evaluated
- Consists of a DME 660 camera engine, power supply and tripod
- Wide FOV of H108° x V77°
- Long operating range up to 10m on white targets in the full field of view
- Camera calibration feature
- Log section to capture single images and movie sequences for further processing
- Many graphic display modes featuring 3D-TOF in color and point cloud presentation, amplitude, grayscale, and DCS

Applications

- Evaluation and development support



Figure 1: Evaluation Kit epc660

1. Precaution and Safety



Eye safety: Do not look directly into the camera under operation. Depending on the mode of operation, the camera device emits highly concentrated non-visible infrared light. It can be hazardous to the human eye. The use of these devices has to follow the safety precautions given in IEC 60825-1 and IEC62471.



The DME 660 camera module is a bare electronic device without a housing around. Therefore, handle it with the necessary ESD precaution.



Over-voltage: Use only power supplies which correspond to the datasheet DME 660 to avoid damage of the DME 660 or cause danger for humans.



Cable-tripping: Place the DME 660 with a tripod on a flat solid ground or fix it correctly on a solid support. Place cables carefully. Falling devices can be damaged or harm persons.



This camera comes with its own calibrated firmware. For proper operation of the camera, upload the correct firmware with the evaluation kit to the camera according the instructions given in the quick guide. Do this when you are changing the camera module.



This camera comes with high quality lens. Do not touch, twist or turn it. Otherwise loss of performance occurs.



EMC compatibility: The DME 660 is designed on module level. It is not an EMC certified device. It is users responsibility to operate it in compliance with the EMC regulations.



The DME 660 is designed on module level. It is NOT a CE, UL, CSA certified device. It is the users responsibility to operate it in compliance with the relevant regulations.



The DME 660 and its software may only be used in accordance of the datasheet DME 660



This device may not be used in safety applications, explosive atmospheres or in radioactive environment.



Limited warranty - Loss of warranty

The DME 660 should only be installed and used by authorized people. All instructions in this datasheet and in the related documents shall be followed and fully complied with. In addition, the installer and user is required to comply with all local laws and regulations. Should any of these instructions not be carefully followed, seriously injury may occur. The installer and user is fully responsible for the safe use and operation of the system. It is the sole responsibility of the installer and the user to ensure that this product is used according to all applicable codes and standards in order to ensure safe operation of the whole application. Any alteration to the devices by the buyer, installer or user may result in unsafe operating conditions. ESPROS Photonics AG is not responsible for any liability or warranty claim which results from such manipulation or disregarding of given operating instructions.

UPDATES

ESPROS Photonics is constantly striving to provide comprehensive and correct product information. Therefore, please check our website regularly for updated versions of datasheets and documentations: www.espros.com



Download the actual Datasheet epc660: www.espros.com → Downloads → Datasheets → Chips



Download the actual Datasheet DME 660: www.espros.com → Downloads → Datasheets → Camera_and_Modules



Download the actual Manual epc660_Evalkit: www.espros.com → Downloads → Datasheets → Evaluation_Kits



Download the current GUI software (client) and the current BeagleBoneBlack software (server).
Questions: Send an email with your request to your local sales office or to info@espros.com.



Update the DME 660 (BeagleBone board): Go to the folder "ESPROS_TOF-imager_Evaluation_Kit_Software_vX.X.X". Read the Readme-file and follow the instructions accordingly.

Table of Contents

1. Precaution and Safety	2
2. epc660 Evaluation Kit	4
2.1. Scope of delivery	4
2.2. Ordering information	4
3. Installation and setup	6
3.1. Fixation of the DME 660	6
3.2. Overview of the DME 660 camera module	6
3.3. Software, software development kit (SDK) and application tools	7
3.4. Exchange of epc660 CC Chip Carrier	7
4. Operation software	8
5. GUI Functionality	9
5.1. Start the GUI software	9
5.2. Overview	10
5.3. Operating mode and display setting	11
5.4. Distance calculation concepts	12
5.5. Miscellaneous functions	13
5.6. Regular greyscale and distance image	14
5.7. Self-illuminated grayscale images created by TOF mode	15
5.8. Mechanical dimensions LED cover	16
5.9. I2C command syntax	16
6. Maintenance and disposal	17
6.1. Maintenance	17
6.2. Disposal	17
7. Addendum	17
7.1. Related documents	17
7.2. Links	17
7.3. Licenses	17

2. epc660 Evaluation Kit

2.1. Scope of delivery



Figure 2: epc660 Evaluation Kit overview

No	Pieces	Designation	Remarks
①	1	Toolbox	
②	1	DME 660-108°/10m	P/N P100 518; with quick release fastener of the tripod
③	1	Power Supply 24V/2.5A	
④	1	Power cord 2 pole EU version and US adapter	Power plug EU Europlug (CEE7/16, 2 pole) Power plug US Type A (NEMA 1-15, 2 pole)
⑤	1	Cable - USB 2.0, A plug - mini-B plug	Length 2m
⑥	1	Plastic bag with Industrial Supply Connector and the toolbox key	The connector can also be inserted in the DME 660
⑦	1	Camera Tripod	
⑧	1	Toolbox belt	
⑨	1	epc660 Quick Start Guide	also available at www.espros.com --> Downloads
	1	DME Cover Plate Set, includes 2 knurled head screw	P/N P100 512, see Figure 16 and Figure 43
		Datasheet DME 660	available at www.espros.com → Downloads
		Datasheet epc660	available at www.espros.com → Downloads
		Application and configuration software, SDK: Use the "ESPROS_TOF-Imager_Evaluation_Kit_Software" for accessing the licensed corresponding tools and software development kit (SDK).	available at www.espros.com → Downloads

Table 1: Bill of material of the delivery

2.2. Ordering information

Part Number	Part Name	Remarks
P100 280	epc660 Evaluation Kit EU & US	Power plug EU Europlug (CEE7/16, 2 pole) & US adapter
P100 512	DME Cover Plate Set	1 set is included in the kit

Table 2: Ordering Information epc660 Evaluation Kit



Figure 3: DME 660 on tripod



Figure 4: epc660 Evaluation Kit



Figure 5: DME 660 tripod mounting

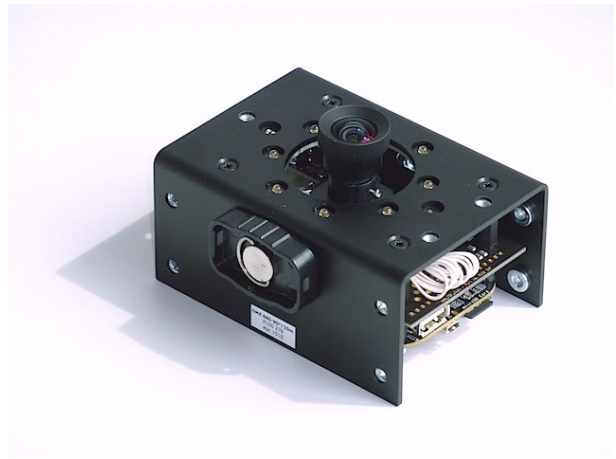

Figure 6: DME 660 with quick release fastener of the tripod

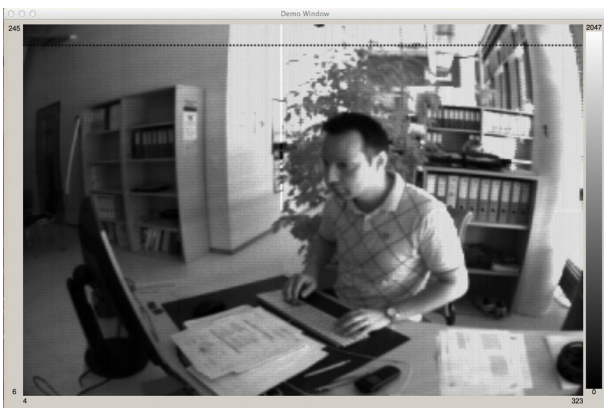

Figure 7: GUI - b&w picture

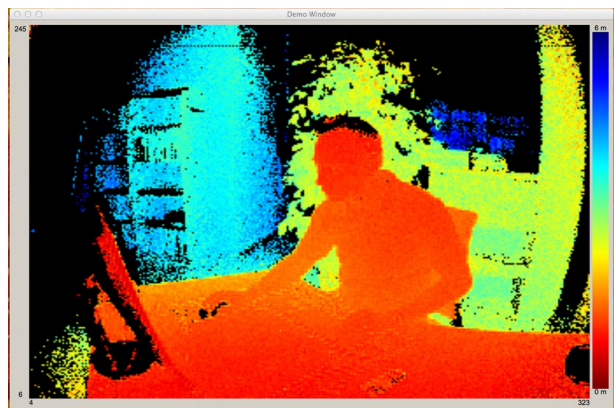
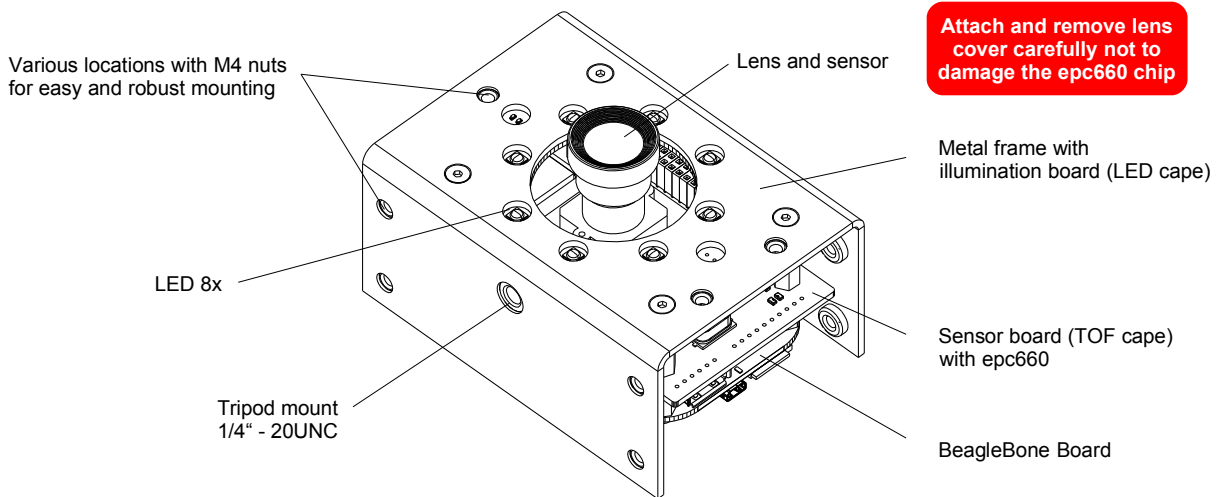

Figure 8: GUI - 3D TOF picture

3. Installation and setup

3.1. Fixation of the DME 660

The DME 660 has various mounting options as shown in Figure 9.



Attach and remove lens cover carefully not to damage the epc660 chip

Figure 9: DME 660 overview

3.2. Overview of the DME 660 camera module

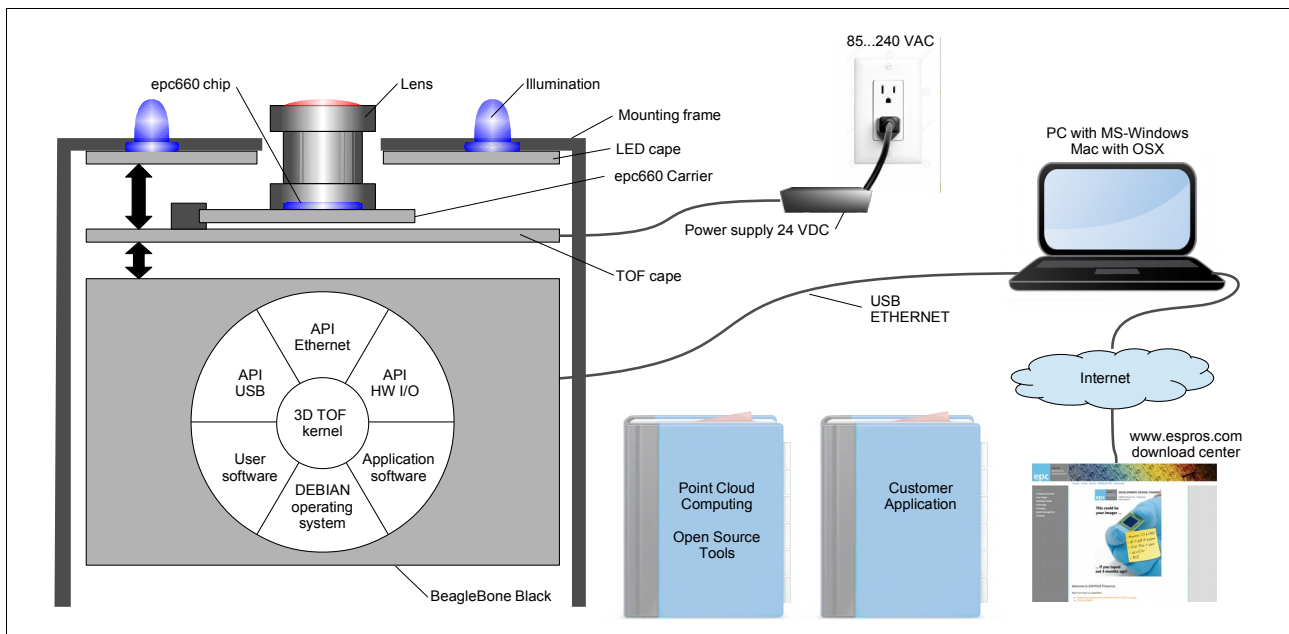

Figure 10: System overview

The epc660 evaluation kit is based on the DME 660 . This is a general purpose camera module based on the epc660 chip:

- The camera is based on a BeagleBone Black (BBB) Linux computer board.
- The TOF cape board communicates with the BBB and carries the epc660 CC Chip Carrier board with the epc660 camera chip and the lens with the lens holder. It carries also the single wire power supply for the whole camera system.
- The camera's active illumination is done by 8 power LEDs on the LED cape which is driven by the TOF cape. The LED cape's metal frame offers two camera mount 1/4" - 20UNC.
- The application software runs on the DEBIAN GNU/Linux operating system. The 3D-TOF kernel manages the camera including correction algorithms. Data for further processing e.g. cloud computing is available on APIs (application programming interface) for USB, Ethernet interfaces or hardware I/O. It opens the world for point cloud computing by using open source tools or by creating own customer applications.

3.3. Software, software development kit (SDK) and application tools

ESPROS Photonics supports the user's development and application by having available various support tools e.g. software development kit (SDK), updates and emulation program downloads for the epc660 chip, application interfaces (API), etc. All they are available by downloading the ESPROS_TOF-Imager_Evaluation_Kit_Software" _vx.x.x. Updates of camera firmware are also included in the package.

After the download, read first the README and CHANGELOG files to get latest operation and application information.

3.4. Exchange of epc660 CC Chip Carrier



Make sure, all assembly procedures are executed on an ESD-compatible workstation.

- Power off the DME 660 and remove cables
- Remove the BeagleBone board
- Remove the TOF cape
- Remove the locking screws from the epc660 CC Chip Carrier
- ⚠ Softly remove the epc660 CC Chip Carrier. The epc660 chip can be destroyed when excessive force is applied.
- Remove lens holder
- Attach the lens holder to the new epc660 CC Chip Carrier
- ⚠ Softly insert the new epc660 CC Chip Carrier
- Insert the locking screws for the epc660 CC Chip Carrier
- Install the TOF cape
- Install the BeagleBone board
- ⚠ First power on the DME 660
- Connect the USB cable
- Download and install on the DME 660 the latest server software according the Readme.txt
- Start the epc660 Evaluation Kit GUI and run a black & white video (start)
- Unlock the fixation of the lens.
- Adjust lens focus
- Lock the fixation of the lens
- Calibrate the DME 660 with this new chip carrier

4. Operation software

The Evaluation Kit epc660 uses software which can be downloaded from the ESPROS Homepage at www.espros.com, click to the link "Downloads" as shown below:

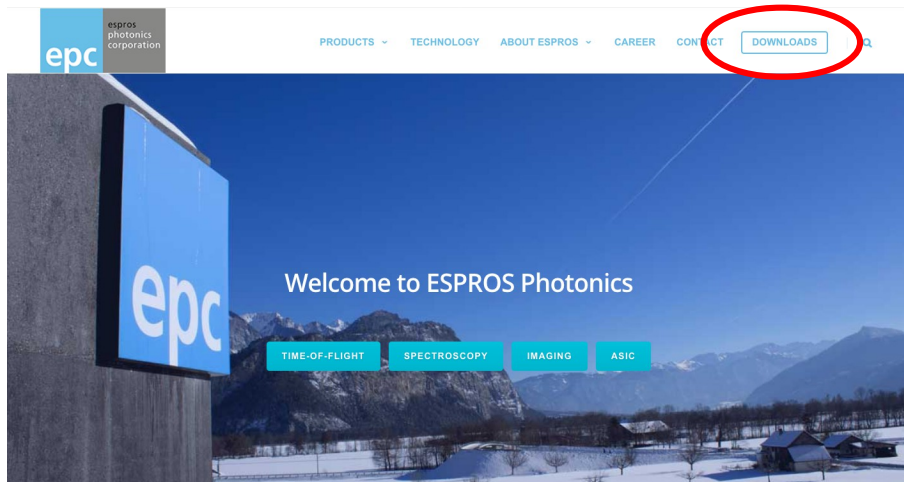

Figure 11: ESPROS homepage with the Download link

You will get a folder structure. Go to the subfolder 03_Evaluation Kits/Evaluationkit_epc660 and download the corresponding file for Windows or Mac of the "ESPROS_TOF-Imager_Evaluation_Kit_Software" _vx.x.x. Unpack the file. You will get a folder structure like shown in Figure 12.

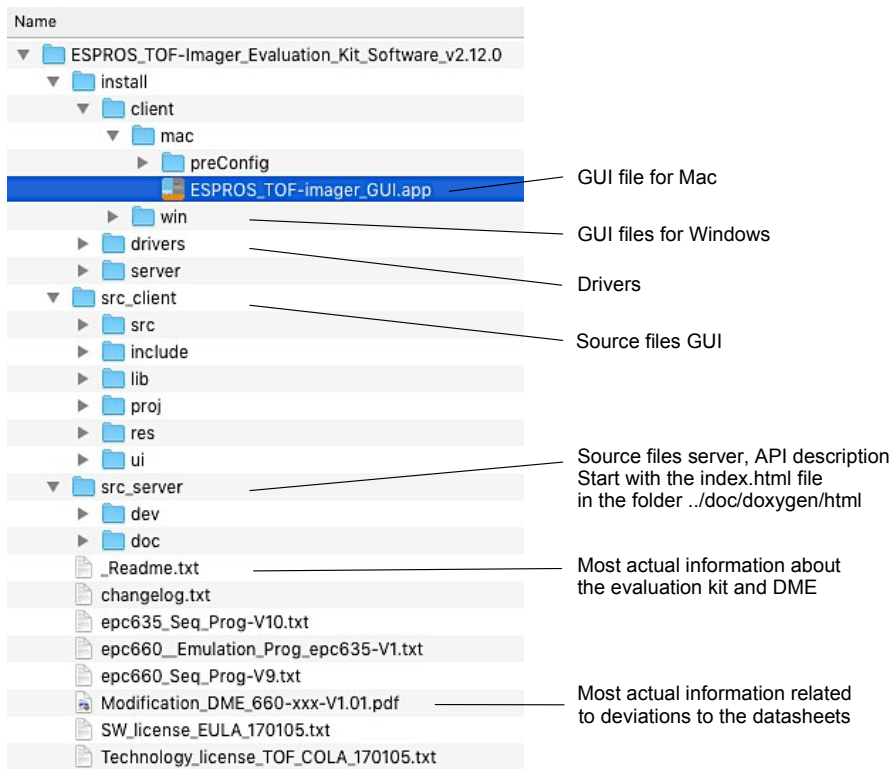

Figure 12: Folder structure after installation

5. GUI Functionality

5.1. Start the GUI software

Note:

First after installation of a new software release, read the files README and CHANGELOG of the download package to get latest evaluation kit information.

After start of the “ESPROS_TOF-imager_GUI” application file, the connect dialog will be displayed.

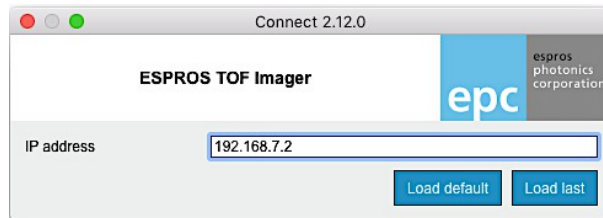

Figure 13: Connect dialog after start up

Following the selection “Load default”, the dialog of preconfigured, basic operation modes appear.

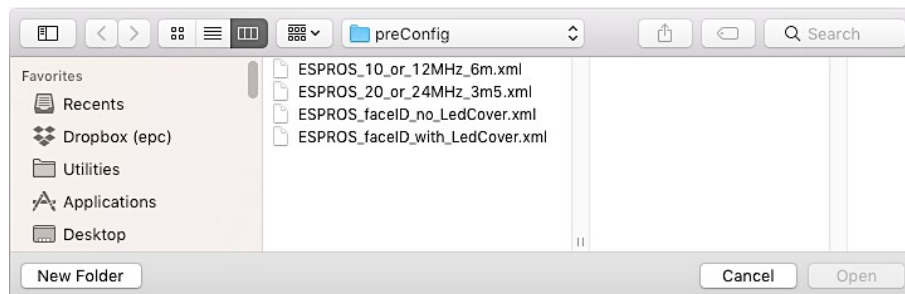

Figure 14: Pre-configurations

Select one of the pre-configurations to start the GUI:

- ESPROS_10_or_12MHz_6m: Basic setup for 6m operating range.
- ESPROS_20_or_24MHz_3m5: Basic setup for 3.5m operating range.
- ESPROS_faceID_no_LedCover: Basic setup for doing Face ID without LED cover.
- ESPROS_faceID_with_LedCover: Basic setup for doing Face ID: This configuration needs a the special LED cover.



Figure 15: Face ID operation



Figure 16: DME with LED cover for face ID

5.2. Overview

The GUI consists of two windows: The control window Figure 17 and the display window Figure 18. The control window is used to set parameters, choose the way of displaying the camera images and to log data. It consists of two section: Left is the dock with the Apps and right is the control section.

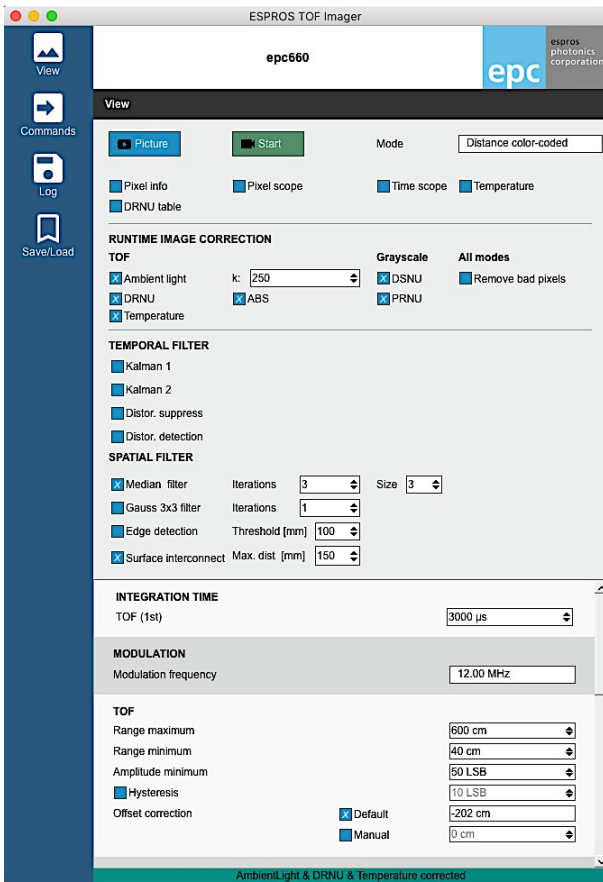

Figure 17: Control window

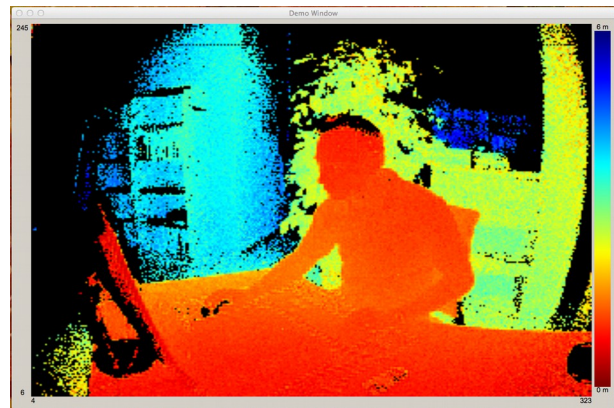
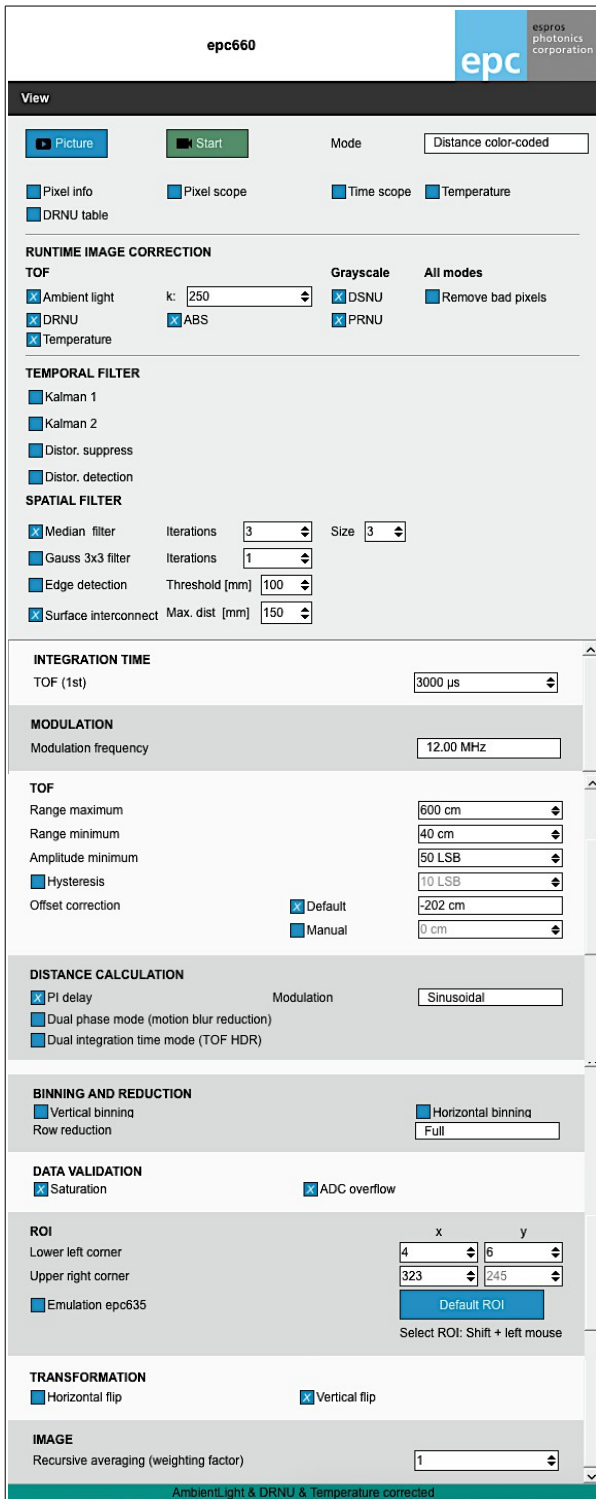

Figure 18: Display window

Most of the functions are self-explaining and are not described here.

5.3. Operating mode and display setting



Displays connected chip type

Notes

Single shot picture or movie
Display mode (grayscale, 3D-TOF, amplitude, DCS, etc.)

Selection for additional information windows e.g Pixel Info: Displays pixel detail data of the pixel pointed by the cursor.

Image and fix pattern noise correction based on calibration. Refer for details to application note AN10 available on www.espros.com, section DOWNLOADS.
ABS: Enables enhanced ambient-light suppression

Smoothing of run-time distance data by temporal filters (Kalman filters). Refer for details to application note AN12 available on www.espros.com, section DOWNLOADS.

Smoothing of run-time distance data by spatial filters. Reduces pixel resolution by increasing picture quality. E.g. the median filter replaces pixel by pixel the value by the median of the selected sliding filter window (size)

Remove erroneous distance data for in-pixel distance transitions e.g. edges
Translation from points into surface in the point cloud function

Integration (or exposure) time for grayscale imaging:
1st Integration time for 3D-TOF imaging
2nd integration time for 3D-TOF high dynamic range imaging (MGX mode)

Select unambiguity distance and distance resolution by setting illumination modulation frequency

3D image data representation setup
Data clipping: upper end of color coding
Data clipping: Lower end of color coding
Set data values with too low signal to maximum distance value
Smooths measurement: Set a hysteresis window for distance value changes
Overall shifting of measured distance values

Distance calculation concept
enabled: Result is based on DCS0 ... DCS3, see Figure 22
DCS0/DCS1 resp. DCS2/DCS3 sampling at same int. time, refer to Table 3
DCS0/DCS1 resp. DCS2/DCS3 sampling with different integration times

Combines 2 vertically adjacent pixel into one (120 rows only)
Combines 2 horizontally adjacent pixel into one (160 columns only)
Shows all, 1/2, 1/4, or 1/8 of the rows
Mark-up of saturated pixels in the picture
Mark-up of overexposed pixels in the picture

Coordinates of displayed pixels
Displays the epc635 pixel-field 160x60 pixel

Flipping of displayed image

Smooths measurement: Averaging of distance values over time

Green underlay: Camera is calibrated for the selected parameters

Figure 19: Operating mode and display setting

Notes:

1. DME 660 supports with calibrations default modulation frequency settings for 12MHz, 24MHz (full range, around 31.5cm/calibration step) and 24MHz face ID (up to 1m, round 2cm/calibration step).



Figure 20: Modulation frequency selection

2. Calibrated parameter. Note: DME's without 24 MHz face ID calibration will use instead the regular 24MHz calibration.

5.4. Distance calculation concepts

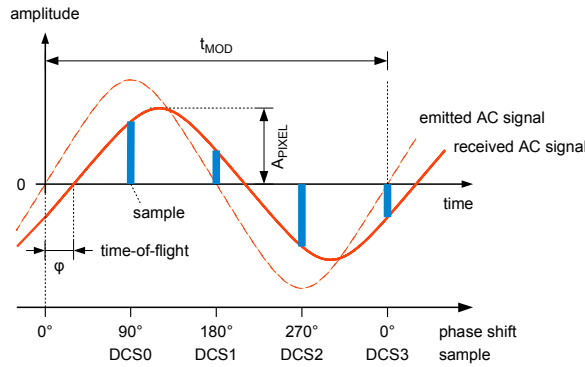

Figure 21: Sampling of the received waveform

There are two check-boxes to choose the way of distance calculation: PI delay and Dual MGX (refer to Figure 19). These functions allow to reduce motion blur and/or accelerate the distance measurement sequence.

	PI Delay	Dual MGX
Enabled	Distance measurement is made by the acquisition of 4 DCS (Differential Correlation Samples). This setting provides the most accurate distance measurement option. Pixel non-linearities are suppressed by differential measurement. Because the distance acquisition is made sequentially by four images, motion blur artifacts occur. This is the default operation mode.	In this mode, in a first acquisition, DCS0 is sampled on the upper row, whereas the DCS1 is sampled into the adjacent lower row. In the second acquisition, DCS2 is sampled on the upper row, whereas the DCS3 is sampled into the adjacent lower row. With these two acquisitions, all 4 DCS are sampled and the distance calculation can take place. Please note that this mode reduces the vertical resolution by 2 (120 rows).
Disabled	Distance measurement is made by the acquisition of 2 DCS. This setting provides a doubled frame rate than with 4 DCS. Also motion blur is reduced. However, pixel non-linearities become visible and therefore, more calibration and compensation is needed.	Full vertical resolution is maintained. This is the default operation mode.

Table 3: PI Delay and Dual MGX mode (motion blur reduction)

Thus, if PI Delay is disabled and Duals MGX is enabled, distance acquisition is made by just on integration. This is the fastest mode which has virtually no motion blur artifact. Figure 22 shows the concepts in a graphical manner.

PI delay = ON	PI delay = OFF
Sampling of the received waveform with DCS0 ...DCS3: π -delay matching (PI delay matching)	Sampling of the received waveform only with DCS0 & DCS1, no PI delay matching
Best image quality (reduced data acquisition offsets) gives full resolution and full sensitivity	Reduced motion blur Doubled 3D TOF frame rate
3D TOF frame rate = 1/4 of DCSx frame rate	Half vertical resolution (half number of rows)

Figure 22: Sampling of the received waveform with or without PI-delay matching

More detailed information regarding the various operating modes can be found in the epc660 datasheet.

5.5. Miscellaneous functions

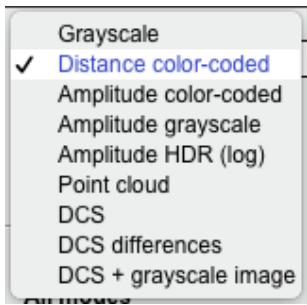

Figure 23: Mode selection overview

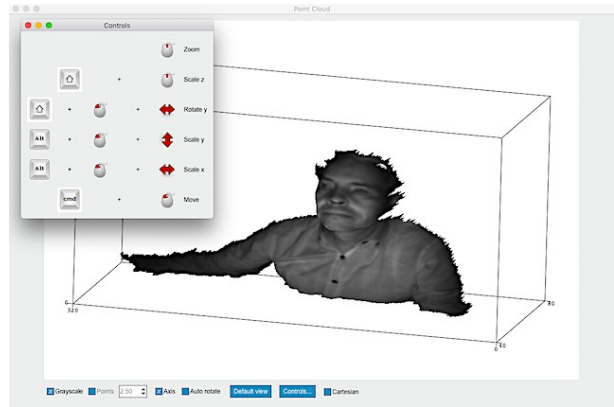

Figure 24: The controls dialog to adjust the point cloud view

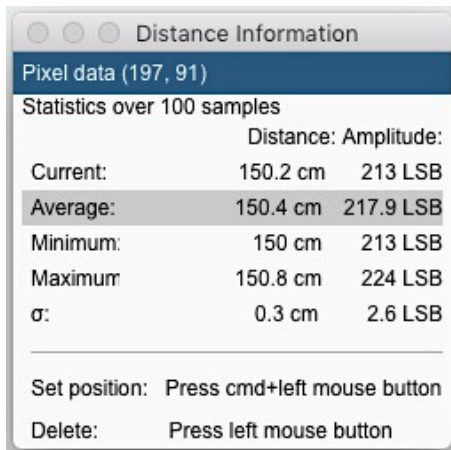

Figure 25: Pixel info

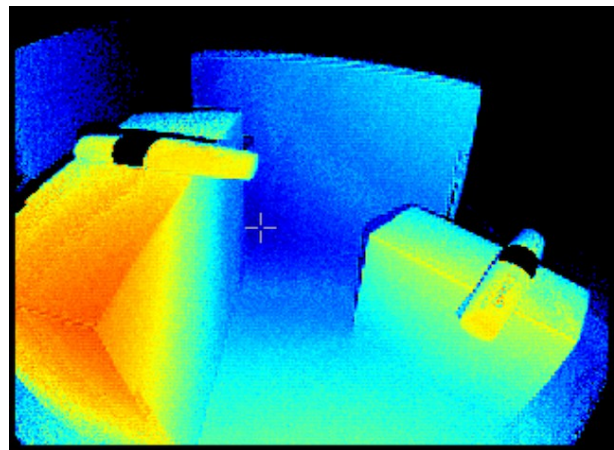

Figure 26: Grey mark-up cross of the pixel info selection

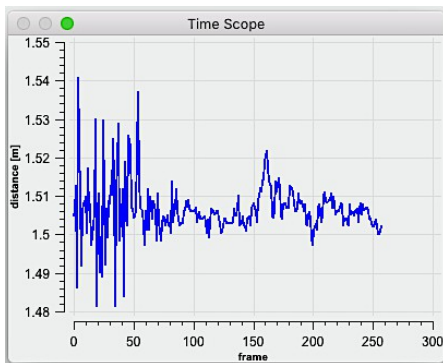

Figure 27: Time sequence data of the pixel info at mark-up

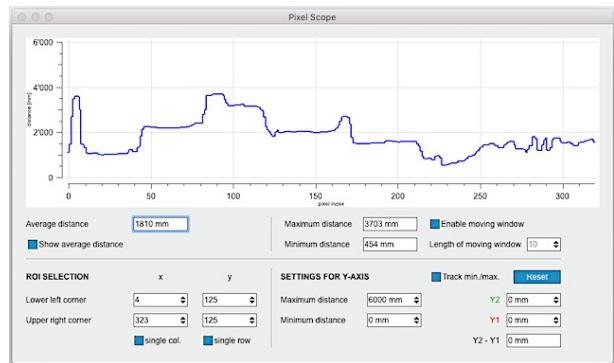

Figure 28: Pixel scope

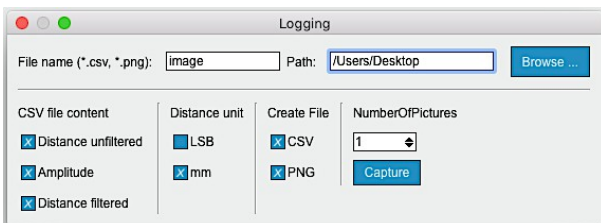

Figure 29: Logging options

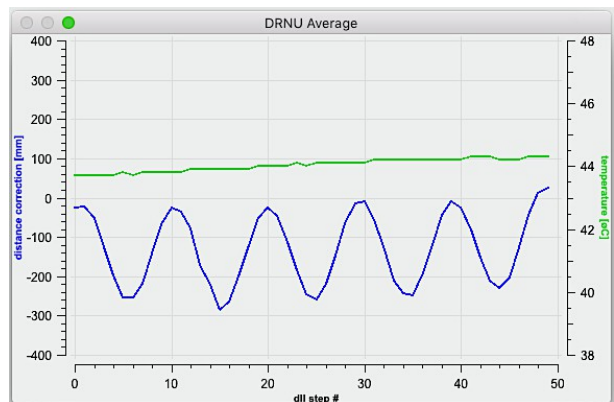

Figure 30: DRNU table for distance corrections

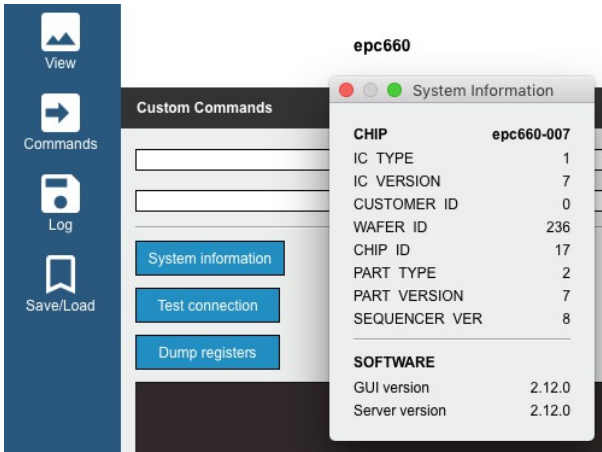

Figure 31: Read system info in the Commands dialog

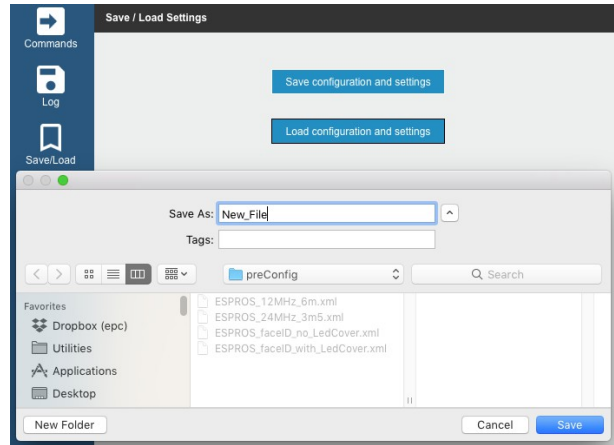

Figure 32: Save and reload system setups in the Save/Load dialog

5.6. Regular greyscale and distance image

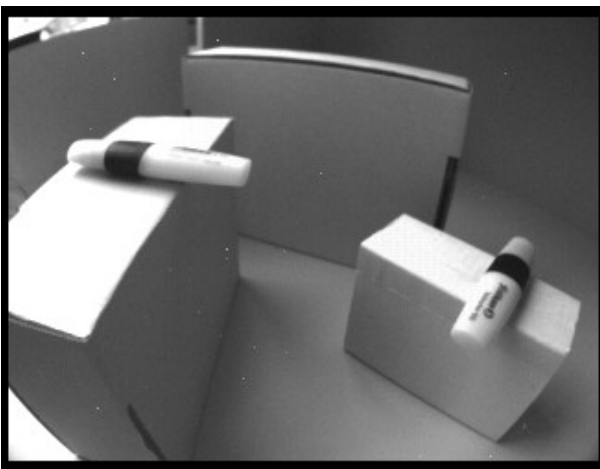

Figure 33: Grayscale picture

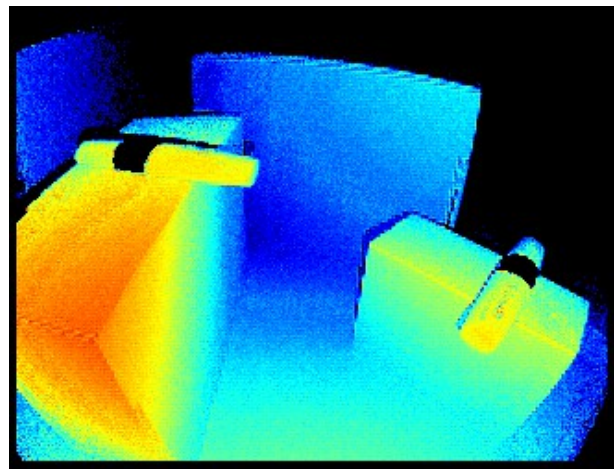

Figure 34: Raw distance picture

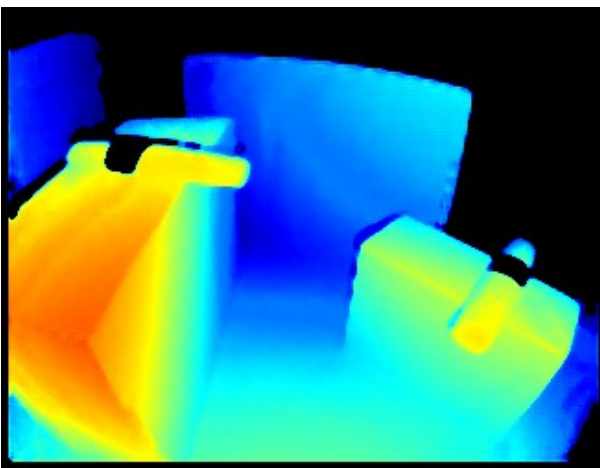

Figure 35: Filtered distance picture

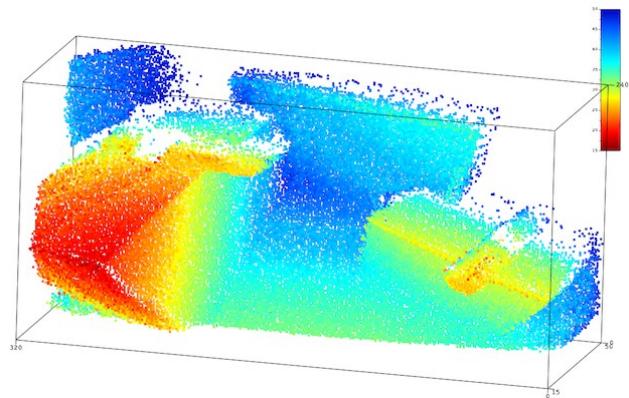

Figure 36: Point cloud

5.7. Self-illuminated grayscale images created by TOF mode

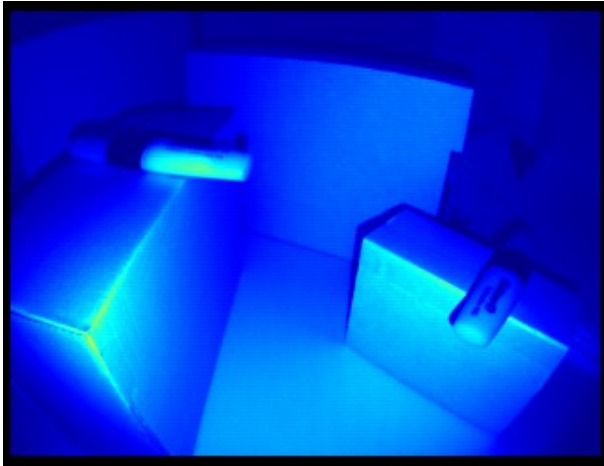

Figure 37: TOF amplitude picture color-coded

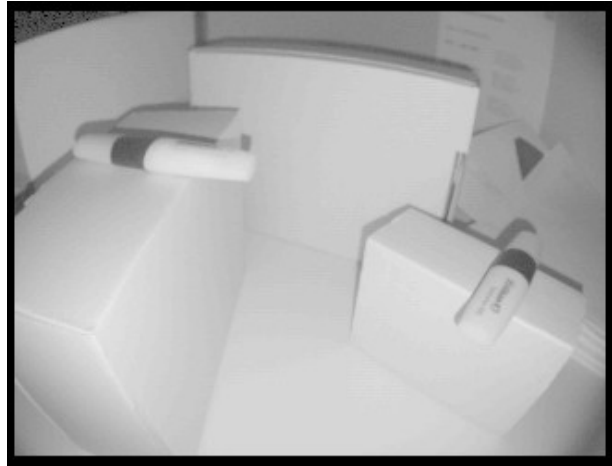

Figure 38: TOF amplitude picture HDR (log)

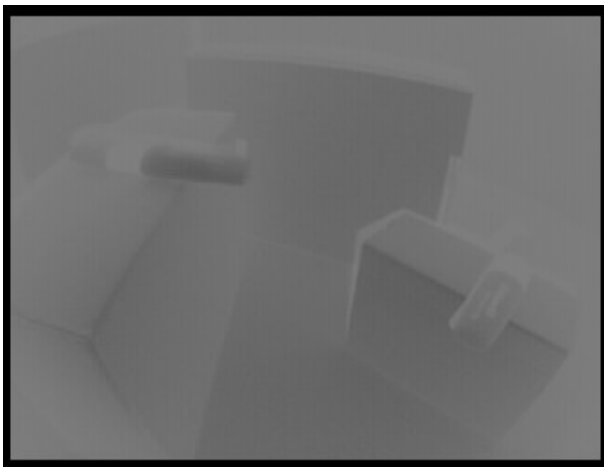

Figure 39: DCS0

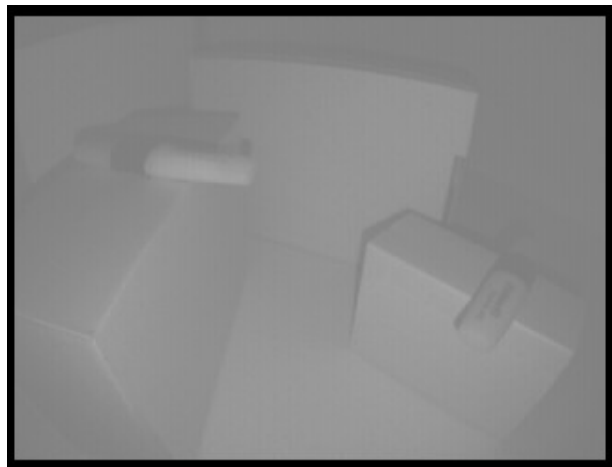

Figure 40: DCS2

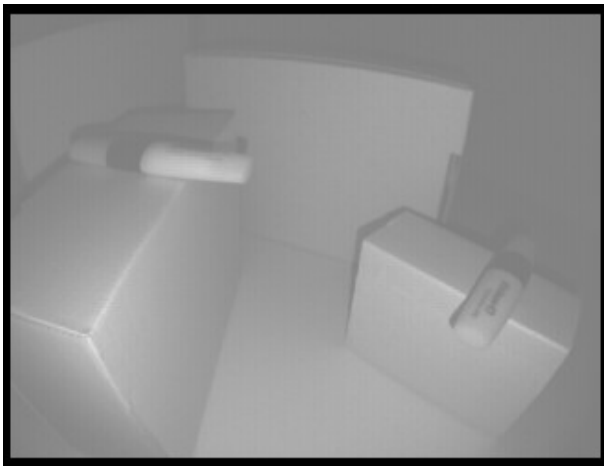

Figure 41: DCS1

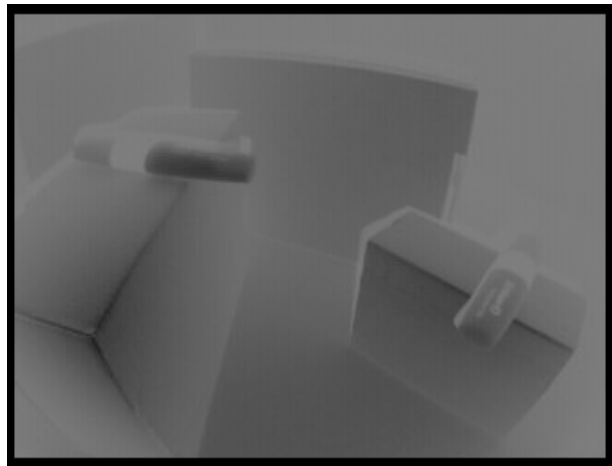

Figure 42: DCS3

5.8. Mechanical dimensions LED cover

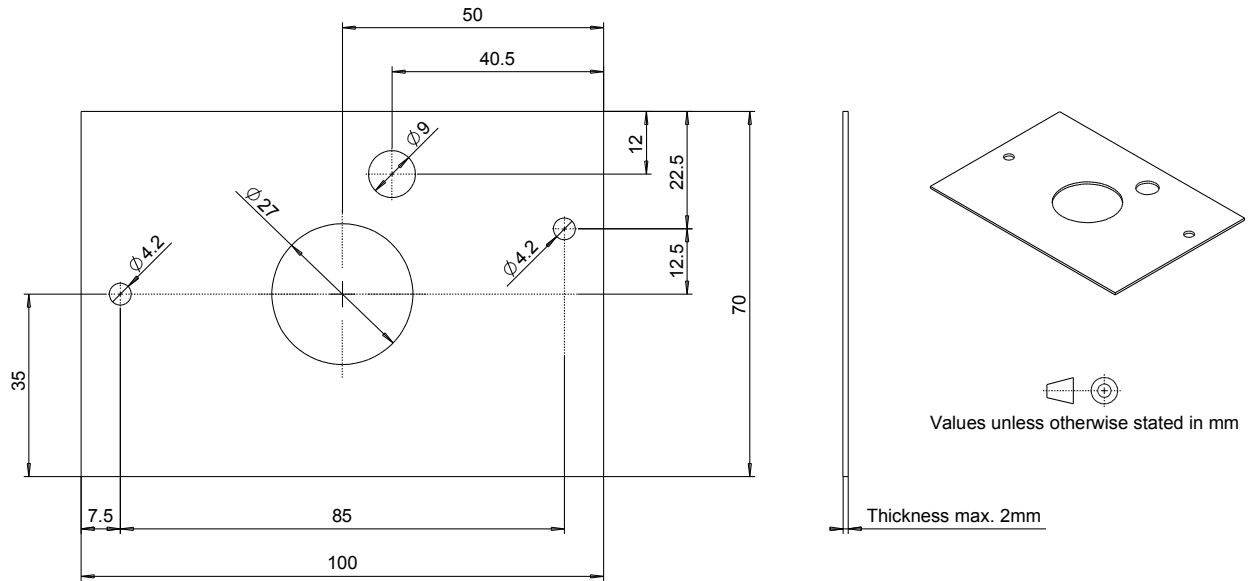

Figure 43: Mechanical dimensions LED cover for face ID and near-field applications. See also Figure 16

5.9. I²C command syntax

The command section / window uses the following syntax for accessing the DME 660 (epc660 chip) by I²C commands:

1. Write to direct address:

Command: w <Direct_address> <Hex value> ---> Response: <01>

Example:

Command: w 92 34 ---> Response: 01

2. Read from direct address:

Command: r <Direct_address> ---> Response: <Hex value>

Example:

Command: r 92 ---> Response: <Hex value>

3. Write to EEPROM (values is active only after power-up or reset)

Command: w 11 <EEPROM_address> <Hex value> ---> Response: <02>

Example:

Command: w 11 92 34 ---> Response: 02

4. Read from EEPROM, data only

Command: w 11 <EEPROM_address> ---> Response: <02>

Command: r 12 ---> Response: <Hex value>

Example:

Command: w 11 92 ---> Response: 01

Command: r 12 ---> Response: <Hex value>

5. Read from EEPROM, EEPROM address and data

Command: w 11 <EEPROM_address> ---> Response: <02>

Command: r11 02 ---> Response: <EEPROM_address> <Hex value>

Example:

Command: w 11 92 ---> Response: 01

Command: r 11 02 ---> Response: 92 <Hex value>

6. Maintenance and disposal

6.1. Maintenance

The components of the device do not need regular maintenance. A functional check is recommended each time the device is taken into operation:

- Check the mounting position and the detection area of the sensor with respect to the operational conditions. Also check that there is no hazardous situation.
- From time to time, clean the lens with a soft towel and with a little soapy water to remove dust or dirt.

6.2. Disposal

Disposal should be done using the most up-to-date recycling technologies for electronic components according to the local regulations and laws. The design and manufacture of the kit's components are done in compliance with the RoHS legal regulations. Traces of dangerous materials may be found in the electronic components, but not in harmful quantities.

7. Addendum

7.1. Related documents

- Datasheet epc660, ESPROS Photonics Corp.
- Application note AN10_Calibration_and_Compensation, ESPROS Photonics corp.
- Application note AN11_DME_660_Photobiological_Safety_Analysis, ESPROS Photonics corp.
- Application note AN12_TOF_data_improvement_toolbox, ESPROS Photonics corp.
- BeagleBone Hardware Specs and Material, BeagleBone Black wiki
- BeagleBone Black System Reference Manual, BeagleBoard.org
- BeagleBone Black, Document No. 450-5500-001 (Schematics), BeagleBoard.org

7.2. Links

www.espros.com

www.beagleboard.org

www.pointcloud.org - Point Cloud Library (PCL)

www.pdal.io - Point Data Abstraction Library (PDAL)

www.opencv.org - OpenCV (OpenSource Computer Vision)

7.3. Licenses

We appreciate the use of the following open source or free software in our tools and respect the large amount of work the owners have done:

- **Putty**: <http://www.chiark.greenend.org.uk/~sgtatham/putty/licence.html>
Copyright (C) 1997-2015 Simon Tatham
- **Qt-4.8**: <http://www.gnu.org/licenses/old-licenses/lgpl-2.1.html>
Copyright (C) 2012 Nokia Corporation
- **Qwt-6.1**: <http://qwt.sourceforge.net/qwtlicense.html>
Copyright (C) 1997 Josef Wilgen & Copyright (C) 2002 Uwe Rathmann under **Qwt License, Version 1.0**
- **QwtPlot3D**: <http://qwtplot3d.sourceforge.net/web/navigation/license.txt>
Copyright (C) 2003-2005 Michael Bieber

All rights reserved by the owners.

THIS SOFTWARE IS PROVIDED BY THE COPYRIGHT HOLDERS AND CONTRIBUTORS "AS IS" AND ANY EXPRESS OR IMPLIED WARRANTIES, INCLUDING, BUT NOT LIMITED TO, THE IMPLIED WARRANTIES OF MERCHANTABILITY AND FITNESS FOR A PARTICULAR PURPOSE ARE DISCLAIMED. IN NO EVENT SHALL THE COPYRIGHT HOLDER OR CONTRIBUTORS BE LIABLE FOR ANY DIRECT, INDIRECT, INCIDENTAL, SPECIAL, EXEMPLARY, OR CONSEQUENTIAL DAMAGES (INCLUDING, BUT NOT LIMITED TO, PROCUREMENT OF SUBSTITUTE GOODS OR SERVICES; LOSS OF USE, DATA, OR PROFITS; OR BUSINESS INTERRUPTION) HOWEVER CAUSED AND ON ANY THEORY OF LIABILITY, WHETHER IN CONTRACT, STRICT LIABILITY, OR TORT (INCLUDING NEGLIGENCE OR OTHERWISE) ARISING IN ANY WAY OUT OF THE USE OF THIS SOFTWARE, EVEN IF ADVISED OF THE POSSIBILITY OF SUCH DAMAGE.

IMPORTANT NOTICE

ESPROS Photonics AG and its subsidiaries (epc) reserve the right to make corrections, modifications, enhancements, improvements, and other changes to its products and services at any time and to discontinue any product or service without notice. Customers should obtain the latest relevant information before placing orders and should verify that such information is current and complete. All products are sold subject to epc's terms and conditions of sale supplied at the time of order acknowledgment.

epc warrants performance of its hardware products to the specifications applicable at the time of sale in accordance with epc's standard warranty. Testing and other quality control techniques are used to the extent epc deems necessary to support this warranty. Except where mandated by government requirements, testing of all parameters of each product is not necessarily performed.

epc assumes no liability for applications assistance or customer product design. Customers are responsible for their products and applications using epc components. To minimize the risks associated with customer products and applications, customers should provide adequate design and operating safeguards.

epc does not warrant or represent that any license, either express or implied, is granted under any epc patent right, copyright, mask work right, or other epc intellectual property right relating to any combination, machine, or process in which epc products or services are used. Information published by epc regarding third-party products or services does not constitute a license from epc to use such products or services or a warranty or endorsement thereof. Use of such information may require a license from a third party under the patents or other intellectual property of the third party, or a license from epc under the patents or other intellectual property of epc.

Resale of epc products or services with statements different from or beyond the parameters stated by epc for that product or service voids all express and any implied warranties for the associated epc product or service. epc is not responsible or liable for any such statements.

epc products are not authorized for use in safety-critical applications (such as life support) where a failure of the epc product would reasonably be expected to cause severe personal injury or death, unless officers of the parties have executed an agreement specifically governing such use. Buyers represent that they have all necessary expertise in the safety and regulatory ramifications of their applications, and acknowledge and agree that they are solely responsible for all legal, regulatory and safety-related requirements concerning their products and any use of epc products in such safety-critical applications, notwithstanding any applications-related information or support that may be provided by epc. Further, Buyers must fully indemnify epc and its representatives against any damages arising out of the use of epc products in such safety-critical applications.

epc products are neither designed nor intended for use in military/aerospace applications or environments unless the epc products are specifically designated by epc as military-grade. Only products designated by epc as military-grade meet military specifications. Buyers acknowledge and agree that any such use of epc products which epc has not designated as military-grade is solely at the Buyer's risk, and that they are solely responsible for compliance with all legal and regulatory requirements in connection with such use.

epc products are neither designed nor intended for use in automotive applications or environments unless the specific epc products are designated by epc as compliant with ISO/TS 16949 requirements. Buyers acknowledge and agree that, if they use any non-designated products in automotive applications, epc will not be responsible for any failure to meet such requirements.