

# PJU Open Frame Power Supply with Integrated DC-UPS

## PJU-60 W Series / PJU-□V60W□□□

# PJU

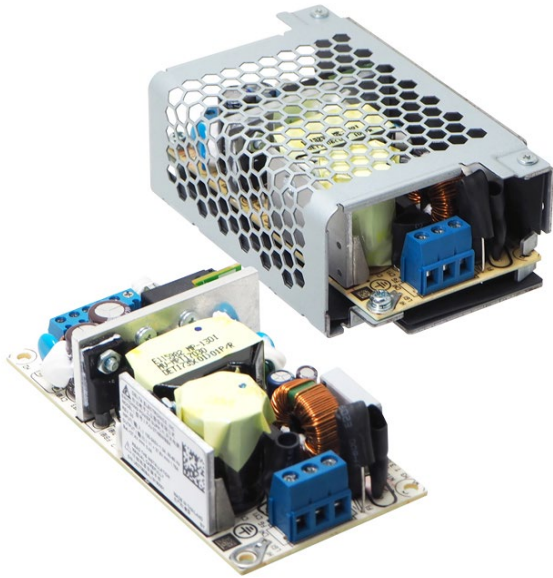

### Highlights & Features

- Universal AC input voltage range
- Zero switch over time from loss of AC to battery operation
- Protection against reverse polarity battery connection
- Built-in diagnostic monitoring for AC OK and Battery Low status
- Overvoltage / Overcurrent / Over Temperature / Short circuit Protections
- Built-in over current and short circuit protection in Buffering (battery discharging) mode operation

### Safety Standards



CB Certified for worldwide use

<b>Model Number:</b>	PJU-□V60W□□□
<b>Unit Weight:</b>	0.25 kg (0.56 lb) (Enclosed) 0.23 kg (0.51 lb) (L Frame) 0.12 kg (0.26 lb) (Open Frame)

### Dimensions (L x W x H):

<b>Enclosed</b>	103.4 x 62 x 37 mm (4.07 x 2.44 x 1.46 inch)
<b>L Frame</b>	103.4 x 61.45 x 37 mm (4.07 x 2.42 x 1.46 inch)
<b>Open Frame</b>	101.6 x 50.8 x 30.6 mm (4.00 x 2.00 x 0.12 inch)

### General Description

Delta PJU series open frame power supply comes with integrated DC-UPS function. The PJU models will switch to battery operation (batteries not included) without interruption to prevent end-product downtime for the customer in the event of power disruption or unexpected loss of AC input power. Consequently, the PJU series can increase the operational reliability of a critical operation. Convection cooling is applied for the single phase design with wide operating temperature range from -20°C to +70°C. The diagnostic monitoring signals for AC OK and Battery Low status will alert the user of any failure through TTL open collector. Metal chassis with case cover is available as option for different installation preferences.

### Model Information

#### PJU Open Frame Power Supply

Model Number	Input Voltage Range	Rated Output Voltage	Rated Output Current
PJU-13V60WC□□	90-264 Vac	13.8 Vdc	V+: 3.5 A, B+: 0.8 A
PJU-13V60WL□□			V+: 3.9 A, B+: 0.4 A
PJU-13V60WB□□			
PJU-27V60WC□□	27.6 Vdc	27.6 Vdc	V+: 1.4 A, B+: 0.75 A
PJU-27V60WL□□			V+: 1.75 A, B+: 0.4 A
PJU-27V60WB□□			

### Model Numbering

PJ	U –	□ V	60 W	□	□	□
Open Frame	Product Series	Output Voltage	Output Power (60 W series)	Package Type	Signal	Connector Type
	U – With DC UPS function	13 V 27 V		C – Enclosed L – L Frame* B – Open Frame*	A – Without Signal* B – With Signal	A – Terminal Block B – JST connector* C – Molex connector*

\*Options

1 | All parameters are specified at 25°C ambient and AC input unless otherwise indicated. (August 2021, Rev.01)



# PJU Open Frame Power Supply with Integrated DC-UPS

## PJU-60 W Series / PJU-□V60W□□□

### Specifications

Model Number	PJU-13V60W□□□		PJU-27V60W□□□	
	V+	B+	V+	B+

### Input Ratings / Characteristics

Nominal Input Voltage	100-240 Vac		
Input Voltage Range	90-264 Vac For power de-rating at 90-115 Vac, see power de-rating on page 6.		
Nominal Input Frequency	50-60 Hz		
Input Frequency Range	47-63 Hz		
Input Current	< 1.2 A @ 115 Vac, < 0.8 A @ 230 Vac		
Efficiency at 100% Load	> 85.0% @ 115 Vac > 86.0% @ 230 Vac		> 88.0% @ 115 Vac > 89.0% @ 230 Vac
Max Power Dissipation	No Load	< 0.30 W @ 115 Vac < 0.45 W @ 230 Vac	< 0.50 W @ 115 Vac < 0.65 W @ 230 Vac
	100% Load	< 13 W @ 115 Vac & 230 Vac	< 9 W @ 115 Vac & 230 Vac
Max Inrush Current (Cold Start)	< 60 A @ 115 Vac & 230 Vac		
Leakage Current	< 0.5 mA / 1.0 mA @ 264 Vac		TN/TT system / IT system

### Output Ratings / Characteristics<sup>1)</sup>

Nominal Output Voltage	13.8 Vdc	13.6 Vdc <sup>2)</sup>	27.6 Vdc	27.4 Vdc <sup>2)</sup>		
Factory Set Point Tolerance	± 2%					
Output Voltage Adjustment Range	13.52-14.00 V	-	27.04-28.00 V	-		
Output Current <sup>3)</sup>	Enclosed	Normal Mode	3.5 A (0-4.3 A)	0.8 A (0-0.8 A)	1.4 A (0-2.15 A)	0.75 A (0-0.75 A)
		Buffering Mode	-	0-4.3 A	-	0-2.15 A
	L Frame	Normal Mode	3.5 A (0-4.3 A)	0.8 A (0-0.8 A)	1.4 A (0-2.15 A)	0.75 A (0-0.75 A)
		Buffering Mode	-	0-4.3 A	-	0-2.15 A
	Open Frame	Normal Mode	3.9 A (0-4.3 A)	0.4 A (0-0.4 A)	1.75 A (0-2.15 A)	0.4 A (0-0.4 A)
		Buffering Mode	-	0-4.3 A	-	0-2.15 A
Output Power	60 W (max)					
Line Regulation	V+	< 0.5% (90-264 Vac @ 100% load)				
Load Regulation	V+	< 1.0% (90-264 Vac @ 0-100% load)				
PARD <sup>4)</sup> (20MHz)	V+	< 100 mVpp				
Rise Time	V+	< 50 ms @nominal input				
Start-up Time	V+	< 3,000 ms @ 115 Vac (100% load), < 1,500 ms @ 230 Vac (100% load)				
Hold-up Time	V+	> 10 ms @ 115 Vac (100% load)				
Dynamic Response (Overshoot & Undershoot O/P Voltage)	V+	± 5%, @ 115-264 Vac input, 0-100% load (Slew Rate: 0.1 A/μS, 50% duty cycle @ 5 Hz to 1 kHz)				
Start-up with Capacitive Loads	V+	3,600 μF at 13.8 Vdc/4.3 A	3,600 μF at 27.6 Vdc/2.15 A			
Voltage Drop Between V+ and B+	Normal Mode	0.2 Vdc typ.				
	Buffering Mode	0.4 Vdc typ.				
Series Operation	No					
Parallel Operation	No					

1) For power de-rating by surrounding air temperature and power de-rating at input voltage, see pages 12-13.

2) If a battery is not connected to B+ and B-, 1.2 Vdc typ. can be found at these terminals when PJU is turned on.

3) The maximum combined output power from V+ and B+ is 60 W at 115-264 Vac input but the output power is reduced to 57 W at 90-110 Vac input  
For example:

60 W; V+: 27.6 V/1.4 A (38.6 W), B+: 27.4 V/0.75 A (20.6) or V+: 27.6 V/2.15 A (59.3 W), B+: 27.4 V/0 A (0 W).

57 W; V+: 27.6 V/1.32 A (36.4 W), B+: 27.4 V/0.75 A (20.6) or V+: 27.6 V/2.06 A (56.9 W), B+: 27.4 V/0 A (0 W).

4) PARD is measured with an AC coupling mode, 5 cm wires, and in parallel with 0.1 μF ceramic capacitor & 47 μF electrolytic capacitor.

# PJU Open Frame Power Supply with Integrated DC-UPS

## PJU-60 W Series / PJU-□V60W□□□

Model Number	PJU-13V60W□□□		PJU-27V60W□□□	
	V+	B+	V+	B+

### Battery Input / Output Characteristics

Nominal Battery Voltage (Batteries not included with power supply)		12 Vdc SLA Sealed lead acid battery	24 Vdc SLA Sealed lead acid battery 2 x 12 Vdc SLA Sealed lead acid battery
Battery Voltage Range	Continuously Operating	11.0 to 13.8 Vdc (nominal at 12 V)	22.0 to 27.6 Vdc (nominal at 24 V)
	Maximum Allowed Voltage	16 Vdc Max	32 Vdc Max
	Battery Low Voltage <sup>1)</sup>	11.5 Vdc typ.	22.5 Vdc typ.
	Minimum Voltage <sup>2)</sup>	10.0 Vdc ± 0.5 Vdc	18.0 Vdc ± 0.5 Vdc
Battery Capacity		3.2 AH – 15 AH	3.2 AH – 7 AH
Charging Time <sup>3)</sup>		< 9hrs ± 1hr for battery 12 V/7 AH	< 10hrs ± 1hr for battery 24 V/7 AH
Buffering Time		Approx. 1hrs 30 mins for battery 12 V/7 AH	Approx. 3hrs for battery 24 V/7 AH
Recommended External Fuse for Battery		Automotive 20 A / 80 V, FK3 type from Littelfuse, or similar in the battery B+ path. The battery fuse protects the wires between the battery and the unit.	
Battery Charging (Normal Mode)		CC-CV mode (constant current-constant voltage)	
End-of-Charge Voltage		The unit always charges battery to a fixed voltage value	

1) The voltage level of battery to enable "BAT Low" function, for PJU-□V60W□□□ model only

2) Minimum battery voltage required for power supply to detect battery in order to begin charging. Battery must be connected to power supply, with the correct polarity, across B+ and B- terminals; and, with input and output loads disconnected.

3) Charging time depends on the state/condition of battery discharge; and will depend on the amount of buffering/discharging time, and load current that battery was discharged at.

# PJU Open Frame Power Supply with Integrated DC-UPS

## PJU-60 W Series / PJU-□V60W□□□

Model Number	PJU-13V60W□□□		PJU-27V60W□□□	
	V+	B+	V+	B+

### Mechanical

Case Chassis / Cover			SECC		
Dimensions (L x W x H)		Enclosed	103.4 x 62 x 37 mm (4.07 x 2.44 x 1.46 inch)		
		L Frame	103.4 x 61.45 x 37 mm (4.07 x 2.42 x 1.46 inch)		
		Open Frame	101.6 x 50.8 x 30.6 mm (4.00 x 2.00 x 0.12 inch)		
Unit Weight		Enclosed	0.25 kg (0.56 lb)		
		L Frame	0.23 kg (0.51 lb)		
		Open Frame	0.12 kg (0.26 lb)		
LED Indicator		Green LED	DC OK		
Cooling System			Convection		
Terminal	PJU-□V60W□□A	Input	3 Pins (Rated 300 V/16 A)		
		Output	<b>PJU-□V60W□AA</b> 4 Pins (Rated 300 V/8 A)		
		Output with Signal	<b>PJU-□V60W□BA</b> 6 Pins (Rated 300 V/8 A)		
	PJU-□V60W□□B	Input	Power Supply Header: B3P5-VH(LF)(SN) Mating Connector: VHR-5N Terminal: SVH-21T-P1.1		
		Output	<b>PJU-□V60W□AB</b> Power Supply Header: B4P-VH(LF)(SN) Mating Connector: VHR-4N Terminal: SVH-21T-P1.1		
		Output with Signal	<b>PJU-□V60W□BB</b> Power Supply Header: B6P-VH(LF)(SN) Mating Connector: VHR-6N Terminal: SVH-21T-P1.1		
	PJU-□V60W□□C	Input	Power Supply Header: 26-62-4051 Mating Connector: 26-03-3051 Terminal: 08-52-0113		
		Output	<b>PJU-□V60W□AC</b> Power Supply Header: 26-60-4040 Mating Connector: 26-03-3041 Terminal: 08-52-0113		
		Output with Signal	<b>PJU-□V60W□BC</b> Power Supply Header: 26-60-4060 Mating Connector: 26-03-3061 Terminal: 08-52-0113		
	Wire	PJU-□V60W□□A	Input	AWG 22-12	AWG 24-12
			Output	AWG 22-16	AWG 24-16
			Output with Signal	AWG 22-16	AWG 24-16
PJU-□V60W□□B		Input	AWG 22-18		
		Output	AWG 22-18		
		Output with Signal	AWG 22-18		
PJU-□V60W□□C		Input	AWG 20-18		
		Output	AWG 20-18		
		Output with Signal	AWG 22-18		
Noise (1 Meter from power supply)			Sound Pressure Level (SPL) < 25 dBA		

# PJU Open Frame Power Supply with Integrated DC-UPS

## PJU-60 W Series / PJU-□V60W□□□

### Buffering Times VS Output Load and Battery Capacity

#### PJU-13V60W□□□

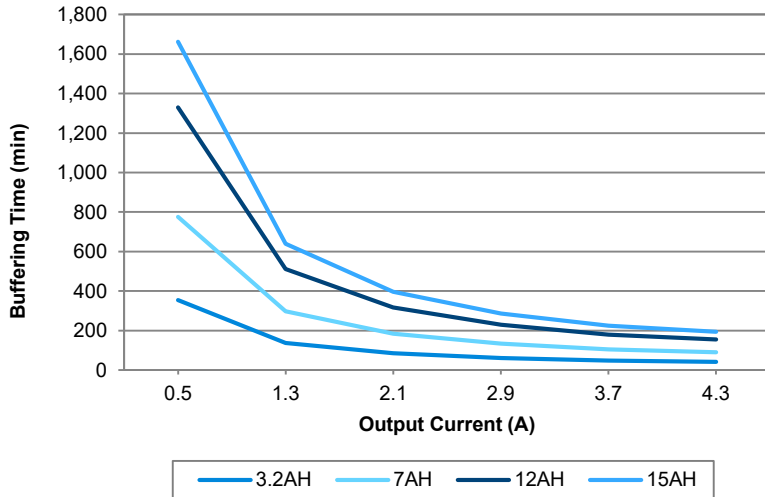

Fig. 1 Buffering Time VS Output Current (PJU-13V60W□□□)

Output Current	Buffering Time			
	3.2 AH	7 AH	12 AH	15 AH
0.5 A	354 m	775 m	1329 m	1662 m
1.3 A	136 m	298 m	511 m	639 m
2.1 A	84 m	185 m	316 m	396 m
2.9 A	61 m	134 m	229 m	286 m
3.7 A	48 m	105 m	180 m	225 m
4.3 A	41 m	90 m	155 m	193 m

These buffering times assume the battery is fully charged to begin with

#### PJU-27V60W□□□

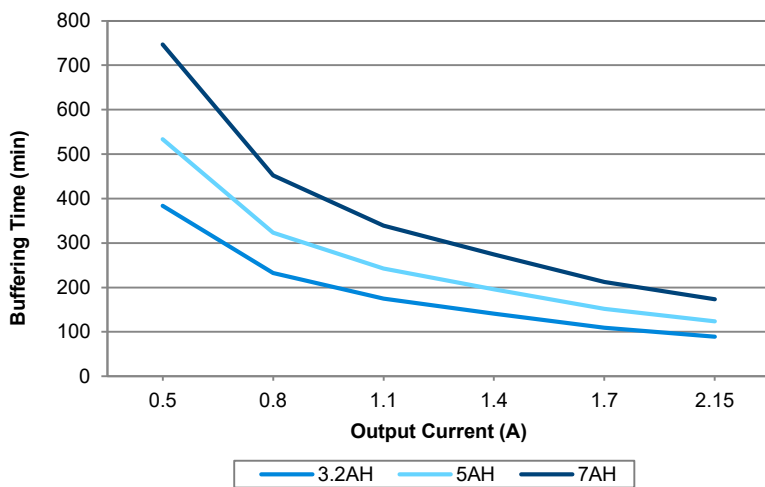

Fig. 2 Buffering Time VS Output Current (PJU-27V60W□□□)

Output Current	Buffering Time		
	3.2 AH	5 AH	7 AH
0.5 A	384 m	533 m	747 m
0.8 A	233 m	323 m	453 m
1.1 A	175 m	242 m	339 m
1.4 A	141 m	196 m	274 m
1.7 A	109 m	152 m	213 m
2.15 A	89 m	124 m	174 m

These buffering times assume the battery is fully charged to begin with

# PJU Open Frame Power Supply with Integrated DC-UPS

## PJU-60 W Series / PJU-□V60W□□□

Model Number	PJU-13V60W□□□		PJU-27V60W□□□	
	V+	B+	V+	B+

### Environment

Surrounding Air Temperature		Operating	-20°C to +70°C
		Storage	-40°C to +85°C
Power De-rating	Temperature	Vertical base mounting	<b>PJU-□V60WC□□ &amp; PJU-□V60WL□□ &amp; PJU-27V60WB□□</b> > 40°C de-rate power by 1.67% / °C
		Vertical side mounting	<b>PJU-13V60WC□□ &amp; PJU-13V60WL□□</b> > 35°C de-rate power by 1.43% / °C <b>PJU-27V60WC□□ &amp; PJU-27V60WL□□</b> > 40°C de-rate power by 1.67% / °C
		Horizontal base mounting	<b>PJU-13V60WB□□</b> > 35°C de-rate power by 1.43% / °C <b>PJU-27V60WB□□</b> > 40°C de-rate power by 1.67% / °C
		Horizontal side mounting	<b>PJU-□V60WC□□ &amp; PJU-□V60WL□□</b> > 35°C de-rate power by 1.43% / °C
	Input voltage	Vertical base mounting	<b>PJU-□V60WC□□ &amp; PJU-□V60WL□□ &amp; PJU-27V60WB□□</b> Power will not de-rate for entire input voltage range
		Vertical side mounting	<b>PJU-□V60WC□□ &amp; PJU-□V60WL□□</b> Power will not de-rate for entire input voltage range
		Horizontal base mounting	<b>PJU-13V60WB□□</b> Output de-rate is required at 90-115 Vac <b>PJU-27V60WB□□</b> Power will not de-rate for entire input voltage range
		Horizontal side mounting	<b>PJU-□V60WC□□ &amp; PJU-□V60WL□□</b> Power will not de-rate for entire input voltage range
Operating Humidity		5 to 95% RH (Non-Condensing)	
Operating Altitude		0 to 5,000 Meters (16,400 ft.)	
Shock Test		Non-Operating	IEC 60068-2-27, Half Sine Wave: 50 G for a duration of 11 ms; 3 times per direction, 9 times in total
		Operating	IEC 60068-2-27, Half Sine Wave: 10 G for a duration of 11 ms; 1 time in X axis
Vibration		Non-Operating	IEC 60068-2-6, Random: 5-500 Hz; 2.09 Grms; 20 min per axis for all X, Y, Z directions
		Operating	IEC 60068-2-6, Sine Wave: 10-500 Hz; 2 G peak; displacement of 0.35 mm; 60 min per axis for all X, Y, Z directions
Over Voltage Category		II	
Pollution Degree		2	

# PJU Open Frame Power Supply with Integrated DC-UPS

## PJU-60 W Series / PJU-□V60W□□□

Model Number	PJU-13V60W□□□		PJU-27V60W□□□	
	V+	B+	V+	B+

### Protections

Overvoltage	V+	<16 V, Latch Mode	<34.8 V, Latch Mode
	B+	16 Vdc Max will not cause damage to the unit	32 Vdc Max will not cause damage to the unit
Overload / Overcurrent	Normal Mode	105-160% of rated load current, Hiccup mode, Non-Latching (Auto recovery)	
	Buffering Mode	4.5-8.0 A, Latch mode	3.0-5.0 A, Latch mode
Over Temperature		Latch mode	
Short Circuit	Normal Mode	Hiccup Mode, Non-Latching (Auto-recovery when the fault is removed)	
	Buffering Mode	Latch mode	
Battery Polarity Protection		Yes	Yes
Wrong Battery Voltage Protection		Yes, 16 Vdc Max will not cause damage to the unit	Yes, 32 Vdc Max will not cause damage to the unit
Deep Discharge Detection <sup>1)</sup>		10.0 Vdc ± 0.5 Vdc	18.0 Vdc ± 0.5 Vdc
Internal fuse at L pin		T3.15 AH	
Protection Against Shock		Class I with PE <sup>2)</sup> connection	

1) Minimum battery voltage required for power supply to detect battery in order to begin charging.

2) PE: Primary Earth

### Reliability Data

MTBF	> 700,000 hrs. as per Telcordia SR-332 I/P: 115 Vac & 230 Vac, Ta: 25°C O/P: 13.8 V/4.3 A for 13 V model and 27.6 V/2.15 A for 27 V model
Expected Cap Life Time	10 years (115 Vac & 230 Vac, 50% load @ 35°C)

### Safety Standards / Directives

Safety Entry Low Voltage		SELV (IEC 60950-1)
Electrical Safety	SIQ Bauart	EN 62368-1
	UL/cUL recognized	UL 60950-1 and CSA C22.2 No. 60950-1 (File No. E191395) UL 62368-1 and CSA C22.2 No. 62368-1 (File No. E191395)
	CB scheme	IEC 60950-1, IEC 62368-1
	UKCA	BS EN 62368-1
CCC		GB 9254, GB 17625.1 and GB 4943.1
CE		In conformance with EMC Directive 2014/30/EU and Low Voltage Directive 2014/35/EU
UKCA		In conformance with Electrical Equipment (Safety) Regulations 2016 No. 1011 and The Electromagnetic Compatibility Regulations 2016 No. 1091
Galvanic Isolation	Input to Output	3.0 KVac
	Input to Ground	1.5 KVac
	Output to Ground	0.5 KVac

# PJU Open Frame Power Supply with Integrated DC-UPS

## PJU-60 W Series / PJU-□V60W□□□

Model Number	PJU-13V60W□□□		PJU-27V60W□□□	
	V+	B+	V+	B+

### EMC

Emissions (CE & RE)		Generic Standards: CISPR 32, EN/BS EN 55032, FCC Title 47: Class B	
Immunity		Generic Standards: EN/BS EN 55024	
Electrostatic Discharge	IEC 61000-4-2	Level 3 Criteria A <sup>1)</sup> Air Discharge: 8 kV Contact Discharge: 6 kV	
Radiated Field	IEC 61000-4-3	Level 3 Criteria A <sup>1)</sup> 80 MHz-1 GHz, 10 V/M with 1 kHz tone / 80% modulation	
Electrical Fast Transient / Burst	IEC 61000-4-4	Level 3 Criteria A <sup>1)</sup> 2 kV (Input power ports)	
Surge	IEC 61000-4-5	Level 3 Criteria A <sup>1)</sup> Common Mode <sup>2)</sup> : 2 kV Differential Mode <sup>3)</sup> : 1 kV	
Conducted	IEC 61000-4-6	Level 3 Criteria A <sup>1)</sup> 150 kHz-80 MHz, 10 Vrms	
Power Frequency Magnetic Fields	IEC 61000-4-8	Criteria A <sup>1)</sup> 10A/Meter	
Voltage Dips and Interruptions	IEC 61000-4-11	0% of 100 Vac, 20 ms 70% of 100 Vac, 500 ms 0% of 100 Vac, 5000 ms 0% of 240 Vac, 20 ms 70% of 240 Vac, 500 ms 0% of 240 Vac, 5000 ms	Criteria A <sup>1)</sup> Criteria A <sup>1)</sup> Criteria B <sup>2)</sup> Criteria A <sup>1)</sup> Criteria A <sup>1)</sup> Criteria B <sup>2)</sup>
Low Energy Pulse Test (Ring Wave)	IEC 61000-4-12	Level 3 Criteria A <sup>1)</sup> Common Mode <sup>2)</sup> : 2 kV Differential Mode <sup>3)</sup> : 1 kV	
Harmonic Current Emission		IEC/EN/BS EN 61000-3-2, Class A, GB17625.1	
Voltage Fluctuation and Flicker		IEC/EN/BS EN 61000-3-3	

1) Criteria A: Normal performance within the specification limits  
 2) Asymmetrical: Common mode (Line to earth)  
 3) Symmetrical: Differential mode (Line to line)

### Block Diagram

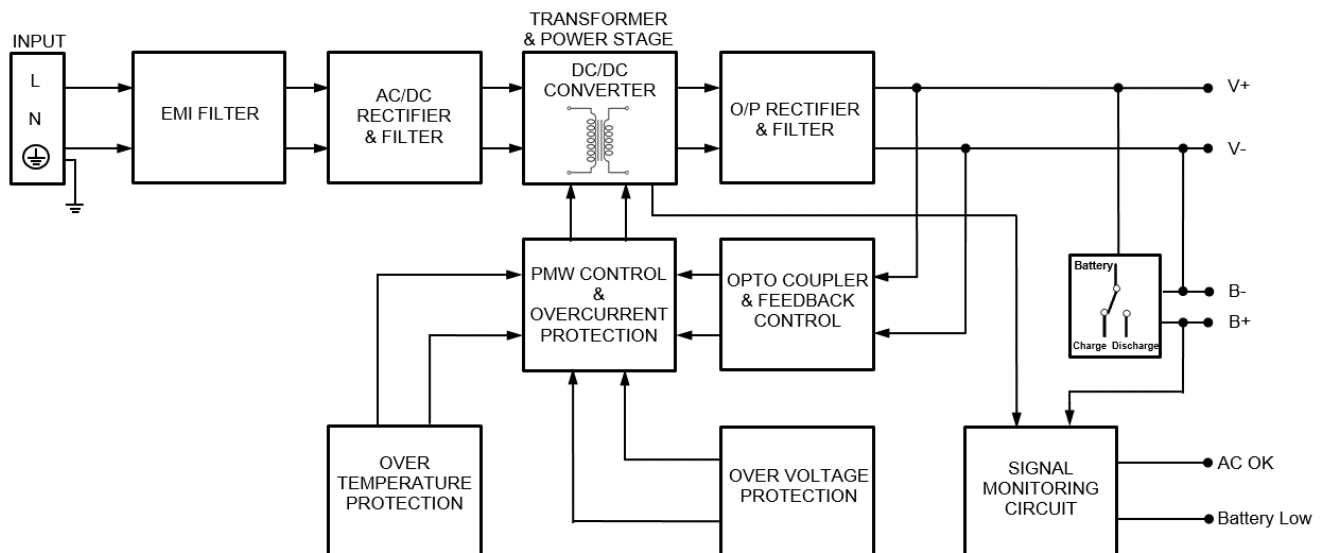



# PJU Open Frame Power Supply with Integrated DC-UPS

## PJU-60 W Series / PJU-□V60W□□□

### Dimensions

- PJU-□V60WC□A: Enclosed with Terminal Block  
L x W x H: 103.4 x 62 x 37 mm (4.07 x 2.44 x 1.46 inch)

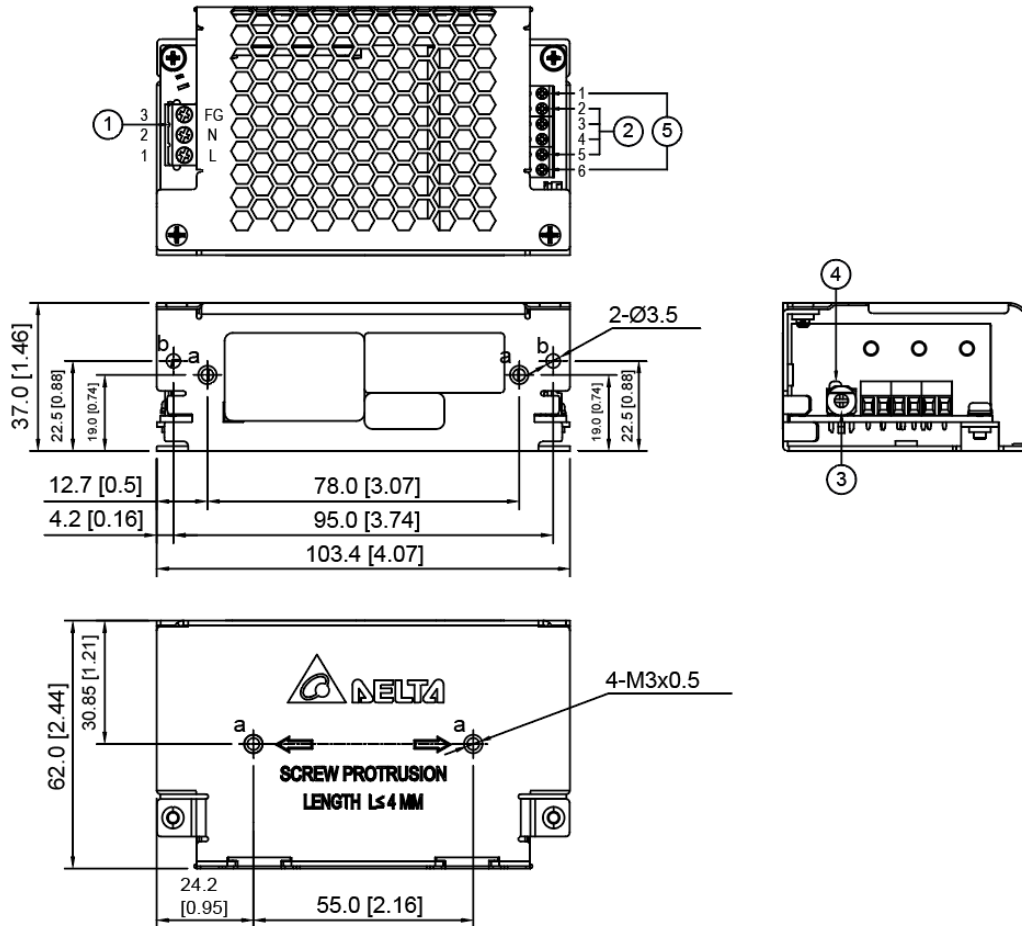

Item	Device Description
1	Input connector Pin 1: Line Pin 2: Neutral Pin 3: FG
2	Output connector Pin 2: V+ Pin 3: V- Pin 4: Battery - Pin 5: Battery +
3	DC voltage adjustment potentiometer
4	DC OK control LED (Green)
5	Signal connector (for PJU-□V60W□B□ only) Pin 1: AC OK Pin 6: Battery Low

Connector Type	
Terminal Block	Harness*

\*Options

# PJU Open Frame Power Supply with Integrated DC-UPS

## PJU-60 W Series / PJU-□V60W□□□

- PJU-□V60WL□A: L Frame with Terminal Block  
L x W x D: 103.4 x 61.45 x 37 mm (4.07 x 2.42 x 1.46 inch)

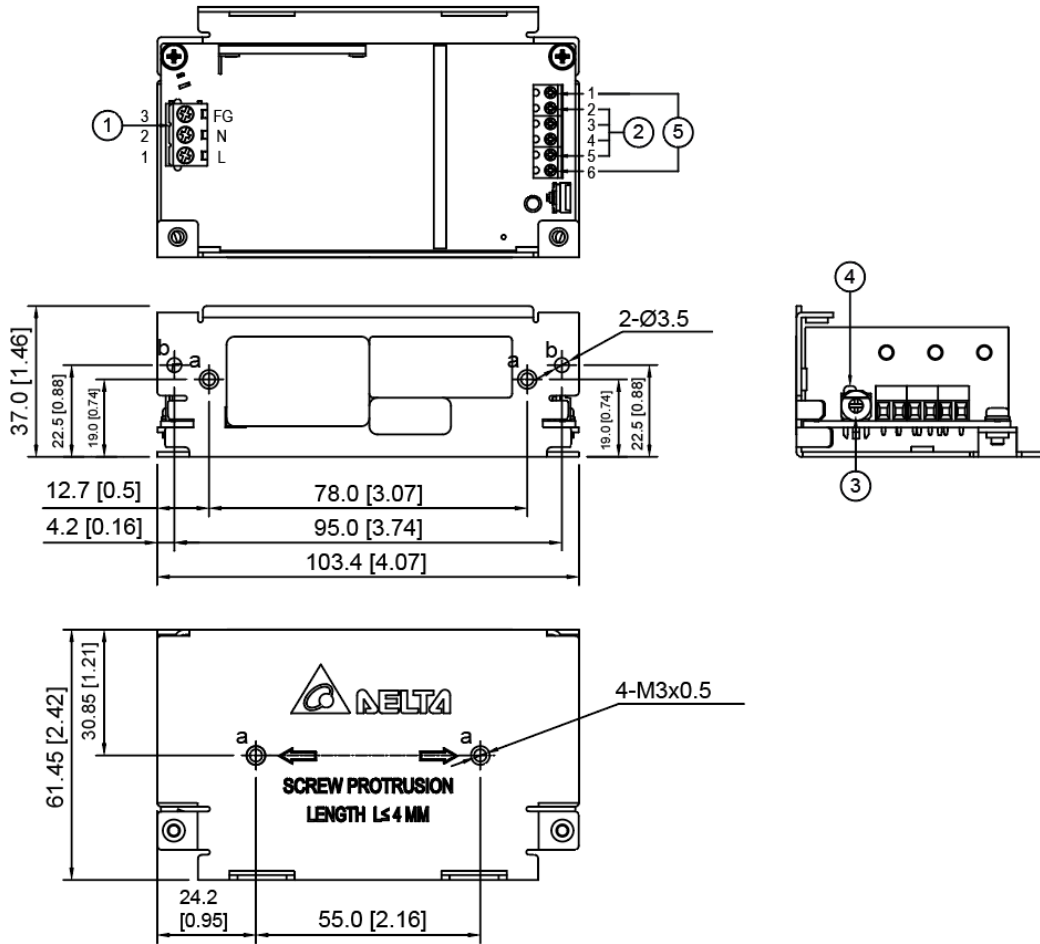

Item	Device Description
1	Input connector Pin 1: Line Pin 2: Neutral Pin 3: FG
2	Output connector Pin 2: V+ Pin 3: V- Pin 4: Battery - Pin 5: Battery +
3	DC voltage adjustment potentiometer
4	DC OK control LED (Green)
5	Signal connector (for PJU-□V60W□B□ only) Pin 1: AC OK Pin 6: Battery Low

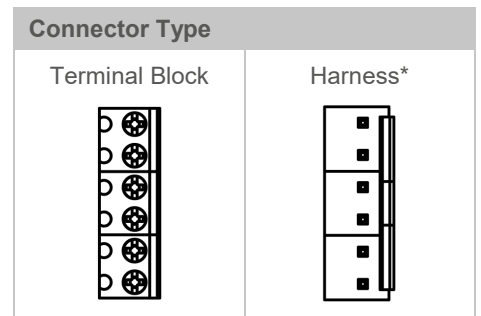

\*Options

# PJU Open Frame Power Supply with Integrated DC-UPS

## PJU-60 W Series / PJU-□V60W□□□

- **PJU-□V60WB□A: Open Frame with Terminal Block**  
**L x W x D: 101.6 x 50.8 x 30.6 mm (4.00 x 2.00 x 1.20 inch)**

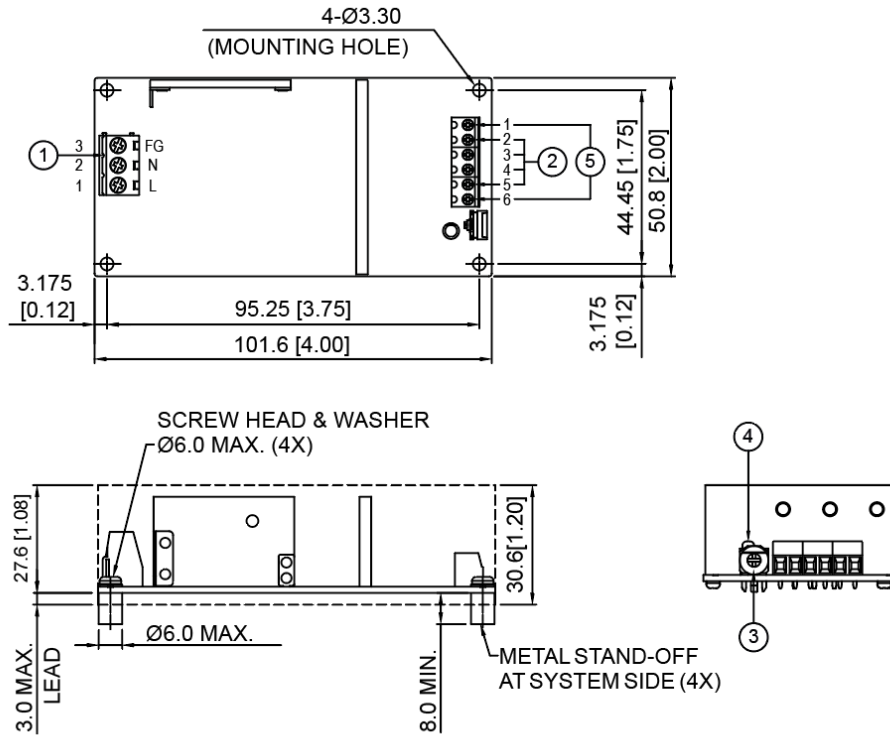

Item	Device Description
1	Input connector Pin 1: Line Pin 2: Neutral Pin 3: FG
2	Output connector Pin 2: V+ Pin 3: V- Pin 4: Battery - Pin 5: Battery +
3	DC voltage adjustment potentiometer
4	DC OK control LED (Green)
5	Signal connector (for PJU-□V60W□B□ only) Pin 1: AC OK Pin 6: Battery Low

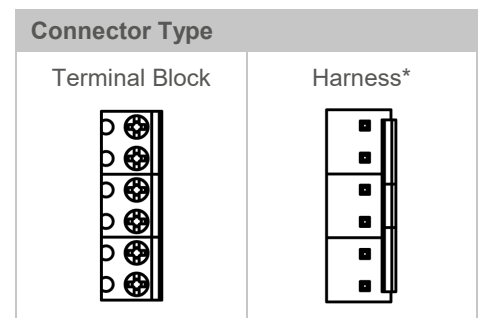

\*Options

# PJU Open Frame Power Supply with Integrated DC-UPS

## PJU-60 W Series / PJU-□V60W□□□

### Engineering Data

#### Output Load De-rating VS Surrounding Air Temperature

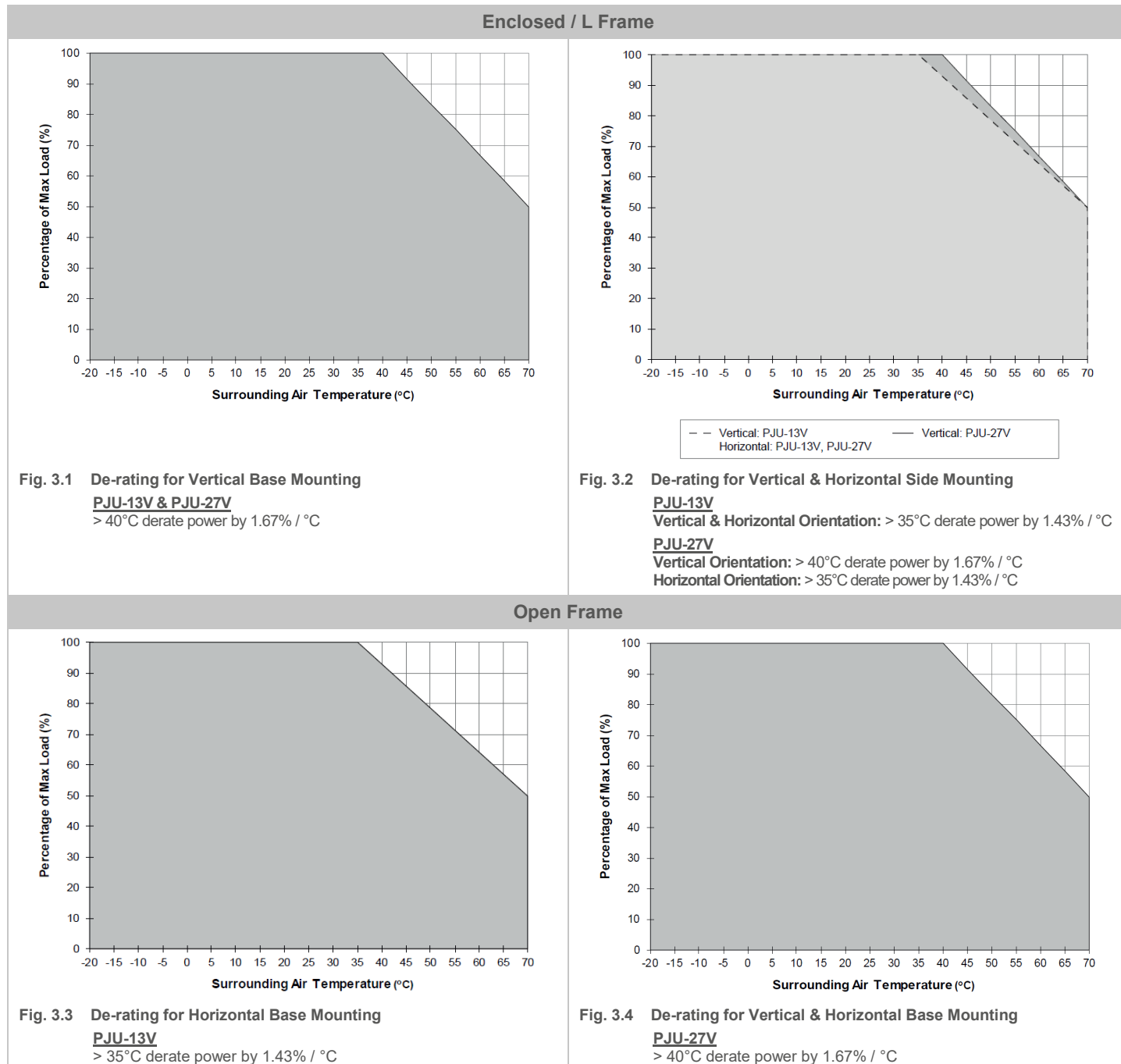

#### Note

1. Power supply components may degrade, or be damaged, when the power supply is continuously used outside the shaded region, refer to the graphs shown in Fig. 3.1-3.4.
2. If the output capacity is not reduced when surrounding air temperature exceeds its specification as defined on Page 6 under "Environment", the device will run into Over Temperature Protection. When activated, the output voltage will go into bouncing mode and will recover when the surrounding air temperature is lowered or the load is reduced as far as necessary to keep the device in working condition.
3. In order for the device to function in the manner intended, it is also necessary to keep a safety distance as recommended in the safety instructions while the device is in operation.
4. Depending on the surrounding air temperature and output load delivered by the power supply, the device can be very hot!
5. If the device has to be mounted in any other orientation, please contact [info@deltapsu.com](mailto:info@deltapsu.com) for more details.



# PJU Open Frame Power Supply with Integrated DC-UPS

## PJU-60 W Series / PJU-□V60W□□□

### Output Load De-rating VS Input Voltage

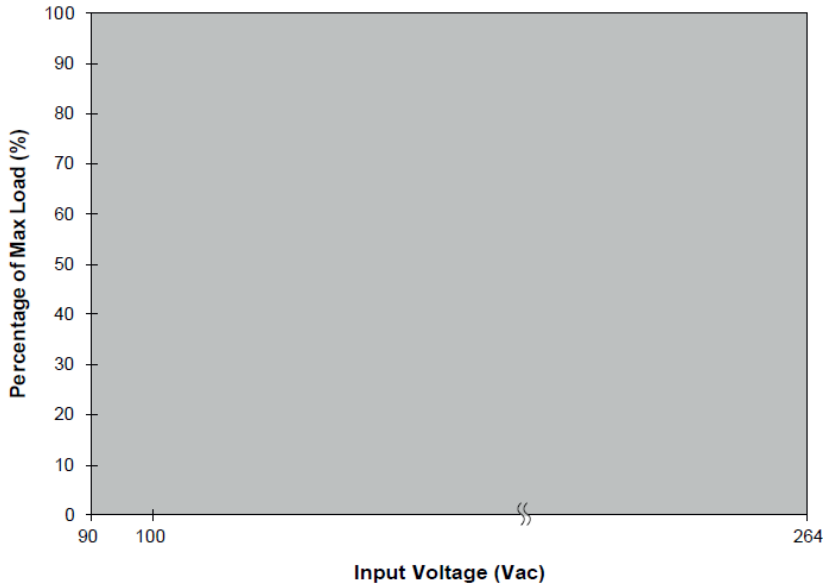

■ No output power de-rating for the input voltage range, refer to Fig. 4.1.

**Fig. 4.1 De-rating for Vertical Base & Side Mounting**  
Enclosed / L Frame

### De-rating for Vertical & Horizontal Base Mounting

Open Frame (PJU-27 V)

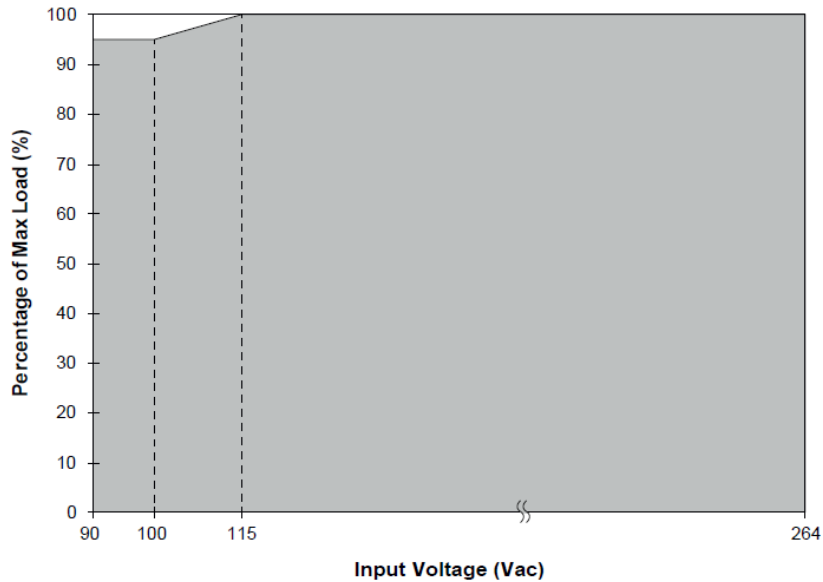

■ Output power de-rating for the input voltage range, refer to Fig. 4.2.

**Fig. 4.2 De-rating for Horizontal Base Mounting**  
Open Frame (PJU-13 V)

# PJU Open Frame Power Supply with Integrated DC-UPS

## PJU-60 W Series / PJU-□V60W□□□

### Assembly & Installation

■ PJU-□V60W□□□ / PJU-□V60W□□□: Enclosed / L Frame



Fig. 5.1 Mounting Hole Locations

- The power supply shall be mounted on a sturdy heat conducting surface with minimum of 2 mounting holes (Fig. 5.1, A) for base mounting or side mounting. Use M3 screws only. The screw penetration into the chassis must be 3.5-4 mm. For the other mounting holes without screw threads, please use suitable screw and nut.
- Recommended mounting tightening torque 4~8 Kgf.cm.

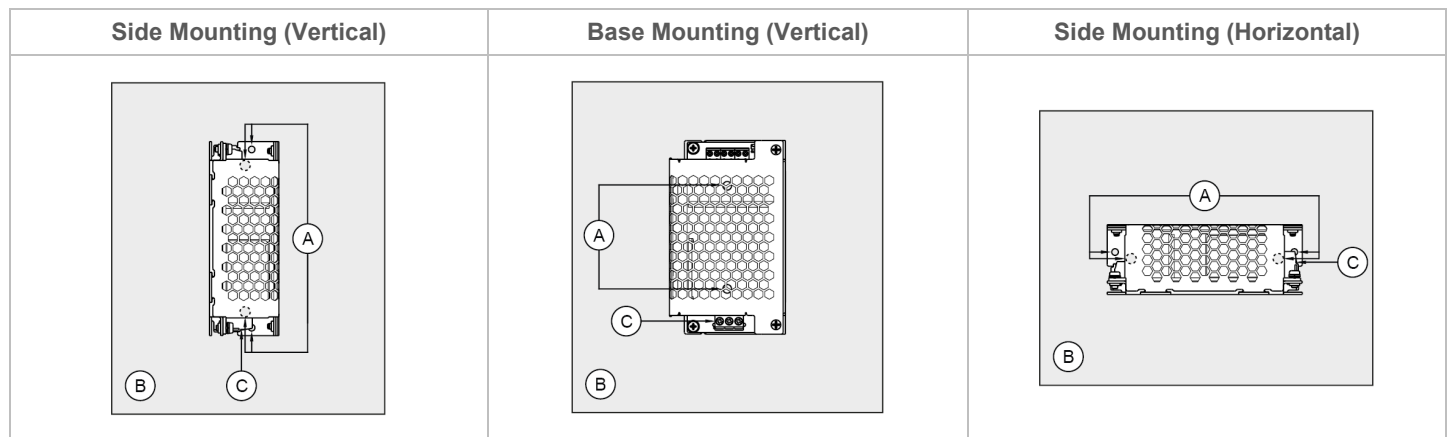

Fig. 5.2 Recommended Mounting Orientations

- Ⓐ Mounting holes for enclosed and L frame type of power supply.
- Ⓑ This surface belongs to customer's end system or panel where the power supply is mounted.
- Ⓒ Input connector

# PJU Open Frame Power Supply with Integrated DC-UPS

## PJU-60 W Series / PJU-□V60W□□□

### ■ PJU-□V60WB□□: Open Frame

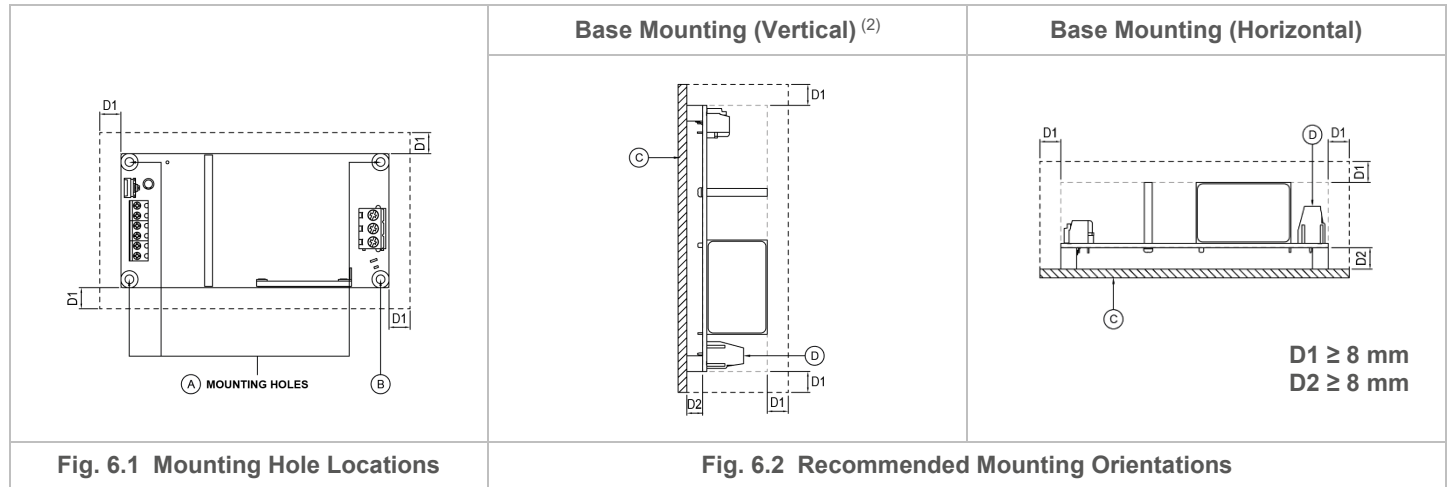

- Ⓐ Mounting holes for open frame type of power supply. <sup>(1)</sup>
- Ⓑ Mounting hole should be connected to the system's protection earthing (PE). <sup>(1)</sup>
- Ⓒ This surface belongs to customer's end system or panel where the power supply is mounted.
- Ⓓ Input connector

Note (1): 4 x Ø3.30 Mounting Holes; Ø6 Max Dimension of Screw Head and Stand-off. Recommended mounting torque for tighten 4~8 Kgf.cm (3.47~6.94 lbf.in).  
 Note (2): For PJU-27V60WB□□ only.

- Please refer AWG number to Mechanical section on Page 4.
- **PJU-□V60W□□A:** Use flexible cable (stranded or solid). The torque of terminal block connector shall not exceed 8 Kgf.cm (7 lbf.in) for input and 2.3 Kgf.cm (2 lbf.in) for output/signal. The stripping length should be 4-5 mm.
- **PJU-□V60W□□B / PJU-□V60W□□C:** Please refer to Table 1 for the recommended Mating Connector and Terminal.

	Input / Output/ Signal	Power Supply Header	Mating Connector	Terminal
<b>B – JST connector*</b>	Input	B3P5-VH(LF)(SN)	VHR-5N	SVH-21T-P1.1
	Output	B4P-VH(LF)(SN)	VHR-4N	SVH-21T-P1.1
	Output with Signal	B6P-VH(LF)(SN)	VHR-6N	SVH-21T-P1.1
<b>C – Molex connector*</b>	Input	26-62-4051	26-03-3051	08-52-0113
	Output	26-60-4040	26-03-3041	08-52-0113
	Output with Signal	26-60-4060	26-03-3061	08-52-0113

\*Options

### Installation of Mounting Accessories

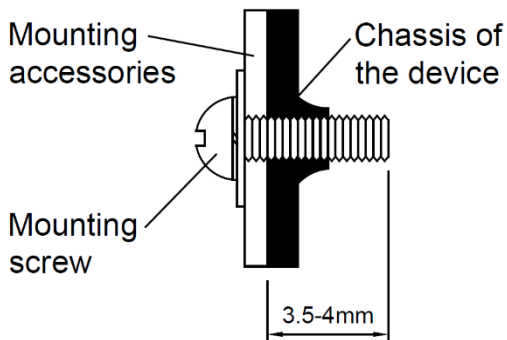

- Only use M3 screw 3.5-4 mm (0.13-0.16 inch) through the base mounting holes. This is to keep a safety distance between the screw and internal components.
- Recommended mounting tightening torque: 4~8 Kgf.cm (3.47~6.94 lbf.in).

# PJU Open Frame Power Supply with Integrated DC-UPS

## PJU-60 W Series / PJU-□V60W□□□

### Safety Instructions

- For enclosed and L frame type of power supply, to ensure sufficient convection cooling, always maintain a distance of  $\geq 50$  mm (1.97 inch) from all surfaces while the device is in operation.
- For open frame type of power supply, please ensure the mounted device is kept at  $\geq 8$  mm (0.32 inch) safety distance for D1 from other components and equipment (Refer to Fig 6.1). Please insert an insulation sheet between the system and product, if the safety distance is  $< 8$  mm (0.32 inch) for D2 (Refer to Fig 6.2).
- The device is not recommended to be placed on low thermal conductive surface, for example, plastics.
- Note that the enclosure of the device can become very hot depending on the ambient temperature and load of the power supply. Do not touch the device while it is in operation or immediately after power is turned OFF. Risk of burning!
- Do not touch the terminals while power is being supplied. Risk of electric shock.
- Prevent any foreign metal, particles or conductors to enter the device through the openings during installation. It can cause: Electric shock; Safety Hazard; Fire; Product failure
- Battery need to be protected from short circuit while installation & servicing. Danger of explosion.
- Signal connector should not interact with AC Input.
- Warning: The power supply must be mounted by metal screws onto a grounded metal surface. When connecting the device, secure Earth connection before connecting L and N. When disconnecting the device, remove L and N connections before removing the Earth connection.  
For open frame type of installation, ensure the power supply's Protective Earthing (marked ⓑ in Fig 6.1) is connected to the system's Protective Earthing (PE). It is also recommended that the input FG be connected to the system's PE.



# PJU Open Frame Power Supply with Integrated DC-UPS

## PJU-60 W Series / PJU-□V60W□□□

### Functions

#### Monitoring Signal Characteristics

The power supply is equipped with monitoring signal outputs for PJU-□V60W□B□ to remote monitoring of the unit.

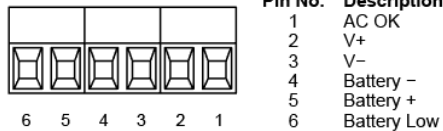

- (1) AC OK and Battery Low monitoring signal outputs are TTL open collector. Must be connected through a pull up resistor to V+ output, or another voltage source.
- (2) The applied voltage should be in the range of 5 V to 28 V with sink current of 2 mA to 30 mA.
- (3) The table below provides the characteristics of monitoring signal functions.

Function	Description	Monitoring Signal Status
AC OK	This signal is active Low when power supply is operating from AC input.	Low <sup>1)</sup>
	This signal changes to active High level when AC input voltage collapses	High <sup>2)</sup>
Battery Low <sup>3)</sup>	This signal turns active Low when battery voltage is lower than 11.5 Vdc typ. for 13 V model and 22.5 Vdc typ. for 27 V model, or when no battery is connected.	Low <sup>1)</sup>
	This signal is active High when battery voltage is higher than 11.5 Vdc typ. for 13 V model and 22.5 Vdc typ. for 27 V model	High <sup>2)</sup>

- 1) Low: 0.5 V with max 30 mA
- 2) High: External applied voltage, 28 V max
- 3) Battery Low status will be changed to Low in buffering mode only.

#### Monitoring Signals Wiring Diagram

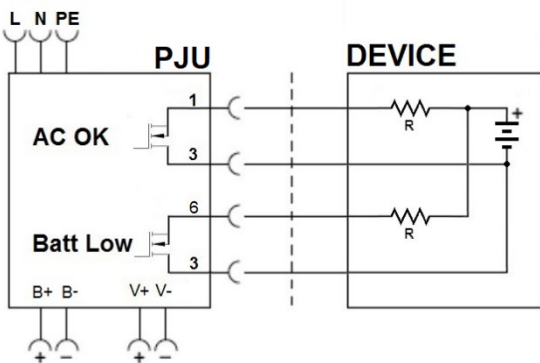

PJU Status	Monitoring Signal status		Green LED Indicator
	AC OK	Battery Low	
PJU OFF	High	High	OFF
Battery Reversed (no AC input)	High	High	OFF
PJU ON <sup>1)</sup> with Battery	Low	High	ON
Battery Charging			
Battery Fully Charged	High	High	ON
Battery Discharging (Buffering Mode)			
Battery Discharging (Low Battery detected)	High	Low	OFF
Output Shutdown	High	High	OFF

1) "PJU ON" means that PJU is operating from AC input voltage

# PJU Open Frame Power Supply with Integrated DC-UPS

## PJU-60 W Series / PJU-□V60W□□□

Normal Mode (Power supply (V+) and Battery charging (B+))

Buffering Mode (Battery discharging (B+))

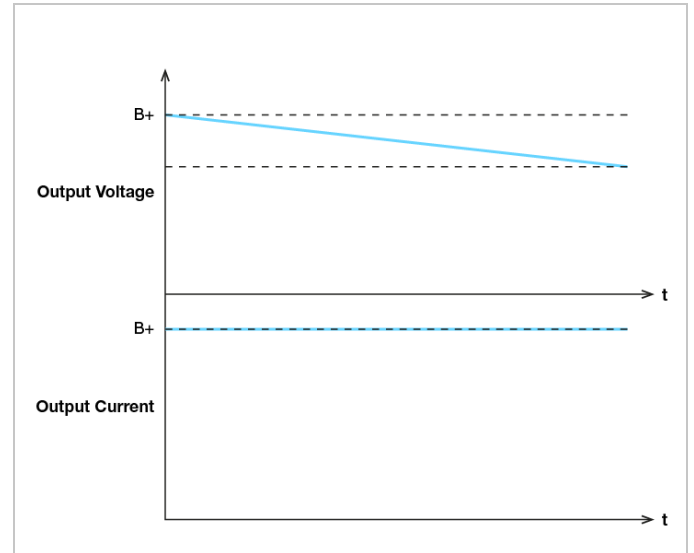
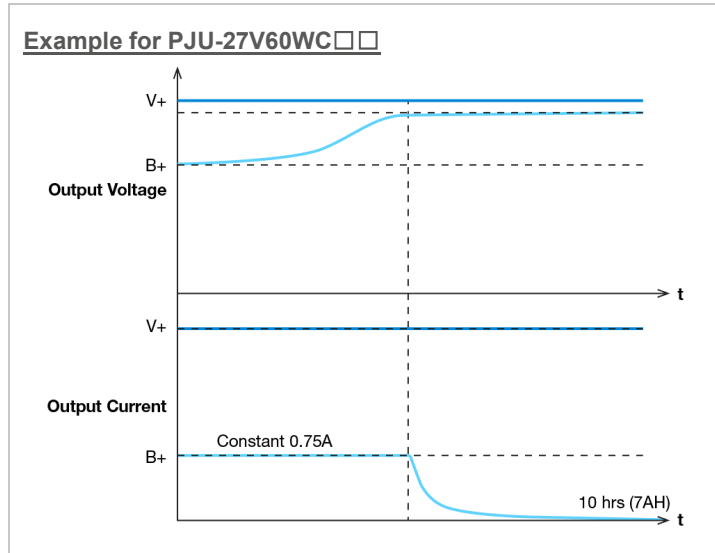

The maximum combined output power from V+ and B+ is 60 W at 115-264 Vac input but the output power is reduced to 57 W at 90-110 Vac input.

For example;

60 W; V+: 27.6 V/1.4 A (38.6 W), B+: 27.4 V/0.75 A (20.6) or V+: 27.6 V/2.15 A (59.3 W), B+: 27.4 V/0 A (0 W).  
 57 W; V+: 27.6 V/1.32 A (36.4 W), B+: 27.4 V/0.75 A (20.6) or V+: 27.6 V/2.06 A (56.9 W), B+: 27.4 V/0 A (0 W).

### Typical Application Notes

**Fig. 7 Provide backup power during AC source interruption or failure**

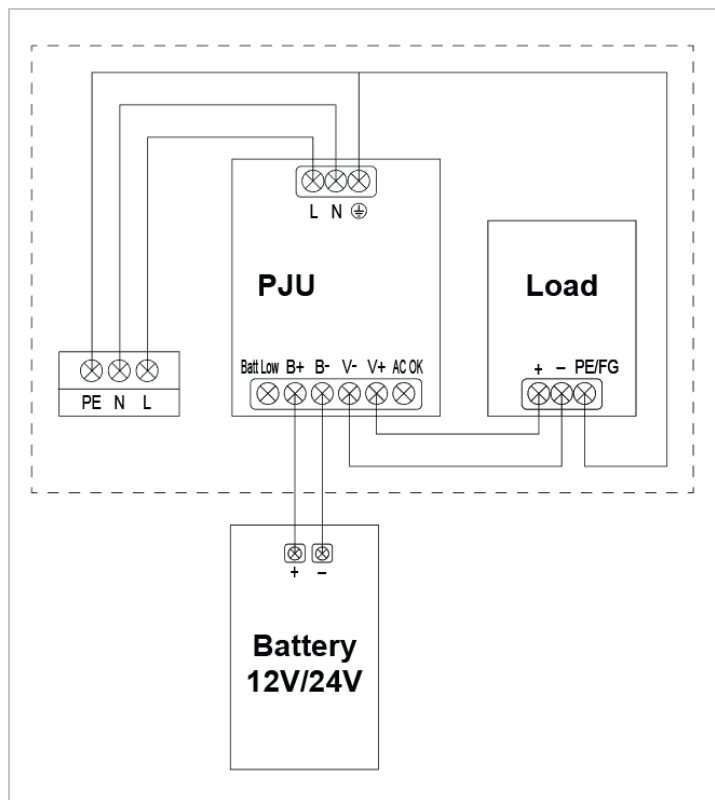

PJU can use as standalone as well and please refer output power to Normal Mode on page 2.

# PJU Open Frame Power Supply with Integrated DC-UPS

## PJU-60 W Series / PJU-□V60W□□□

■ Graph illustrating the Start-up Time, Rise Time, and Hold-up Time

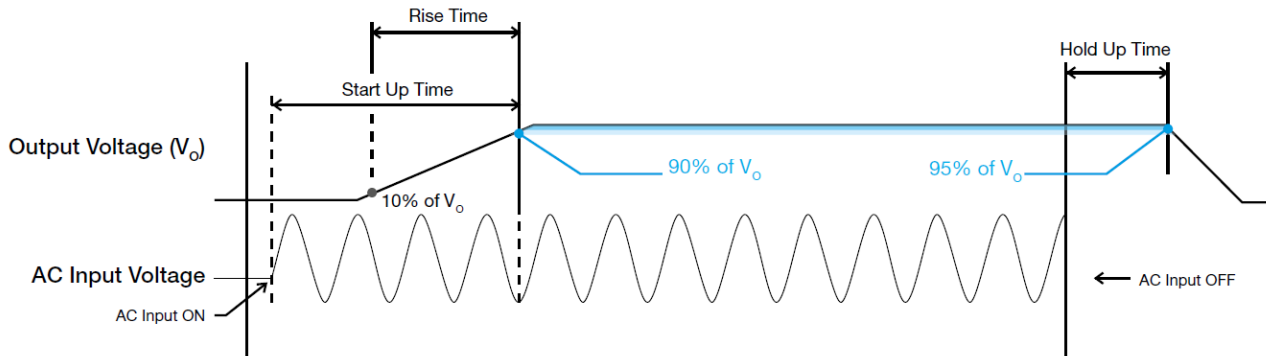

### Start-up Time

The time required for the output voltage to reach 90% of its final steady state set value, after the input voltage is applied.

### Rise Time

The time required for the output voltage to change from 10% to 90% of its final steady state set value.

### Hold-up Time

Time between the collapse of the AC input voltage, and the output falling to 95% of its steady state set value.

### Inrush Current

Inrush current is the peak, instantaneous, input current measured and, occurs when the input voltage is first applied. For AC input voltages, the maximum peak value of inrush current will occur during the first half cycle of the applied AC voltage. This peak value decreases exponentially during subsequent cycles of AC voltage.

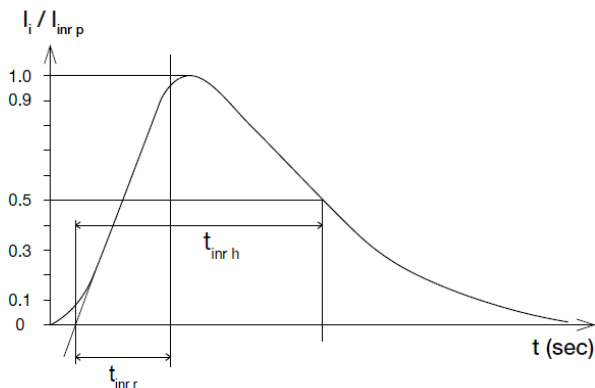

### Dynamic Response

The power supply output voltage will remain within  $\pm 5\%$  of its steady state value, when subjected to a dynamic load from 0% to 100% of its rated current.

■ 50% duty cycle / 5 Hz to 1 KHz

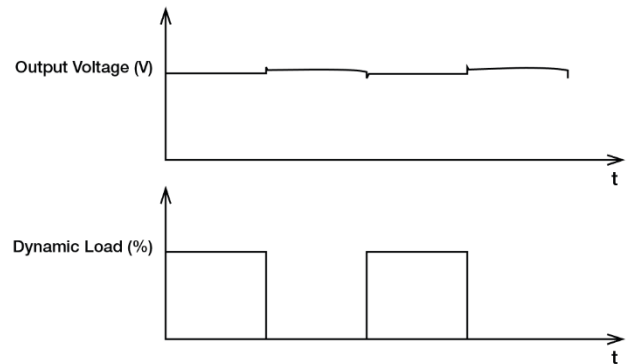

# PJU Open Frame Power Supply with Integrated DC-UPS

## PJU-60 W Series / PJU-□V60W□□□

### Overload & Overcurrent Protections (Auto-Recovery and Latch Mode)

The behavior of the power supply's Overload (OLP) and Overcurrent (OCP) Protections depend on whether the unit is operating in the Normal Mode, or the Buffering Mode.

#### Normal Mode (Operation from AC input Voltage)

In the event of an output current ( $I_o$ ) within 105% to 160% of Max load the output voltage ( $V_o$ ) will start to droop. Once the power supply has reached its maximum power limit, the protection is activated; and, the power supply will go into "Hiccup mode" (Auto-Recovery). The power supply will recover once the fault condition of the OLP or OCP is removed and  $I_o$  is back within the specified range.

The power supply will go into Hiccup mode (Auto-Recovery).

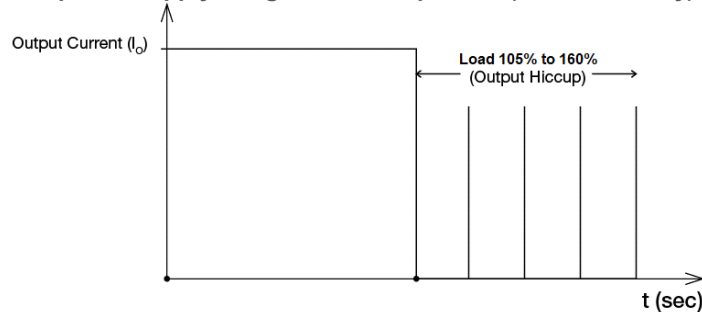

#### Buffering Mode (Operation from Battery)

When the output current exceeds the maximum specified output value, the unit will latch. The power supply can be re-started by removing the fault; and, re-application of input AC voltage.

The power supply will Latch in Buffering Mode.

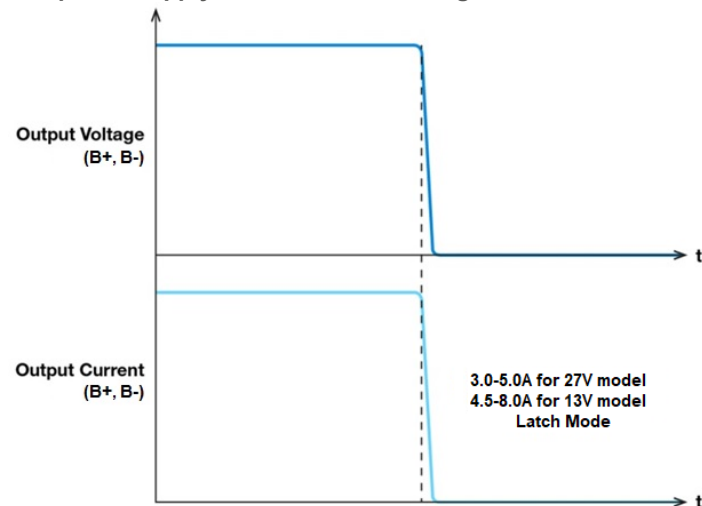

### Short Circuit Protection (Auto-Recovery)

The power supply's output OLP/OCP function also provides protection against short circuits. When a short circuit is applied, the output current will operate as shown in the illustration in the OLP/OCP section on this page.

**Normal Mode: The power supply will go into Hiccup mode (Auto-Recovery).**

**Buffering Mode: The power supply will Latch.**

### Overvoltage Protection (Auto-Recovery)

The power supply's overvoltage circuit will be activated when its internal feedback circuit fails. The output voltage shall not exceed its specifications defined on Page 7 under "Protections".

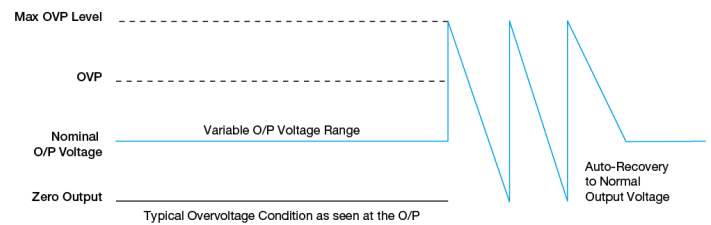

### Over Temperature Protection (Latch Mode)

As described in load de-rating section, the power supply also has Over Temperature Protection (OTP). In the event of a higher operating temperature at 100% load; or, when the operating temperature is beyond what is recommended in the de-rating graph, the OTP circuit will be activated. When activated, power supply will latch, until the surrounding air temperature drops to its normal operating temperature or the load is reduced as recommended in the de-rating graph. Removal/re-application of input AC voltage will then be required in order to restart.

# PJU Open Frame Power Supply with Integrated DC-UPS

## PJU-60 W Series / PJU-□V60W□□□

### Troubleshooting

#### PJU-□V60W□A□ (without Signal) and PJU-□V60W□B□ (with Signal)

Problem	Possible Cause	Suggestion
PJU does not operate in normal mode after AC is applied	Input wiring is open or input voltage to the supply is not available.	Check wiring and voltage of input supply.
	Internal fuse is opened.	Contact your local Delta sales support group.
PJU does not operate in Buffering mode after AC is collapsed	Battery wiring is not connected or opened.	Check battery wiring and compare with Typical Application Notes in this PJU datasheet. Make corrections as needed.
	Battery polarity is not corrected.	Check battery polarity. Make corrections as needed.
	Battery did not have enough time to be charged and it is still below the continuous operating voltage range.	Check battery voltage and compare with minimum required battery voltage provided in this PJU datasheet.
PJU does not charge and discharge battery	Battery polarity is not corrected.	Check battery polarity. Make corrections as needed.
	Battery is damaged.	Check battery and replace as needed.

#### PJU-□V60W□B□ (with Signal)

Problem	Possible Cause	Suggestion
Battery Low signal status is Low (Buffering mode)	Battery is discharged and its voltage is lower than 11.5 Vdc typ. for 13 V model and 22.5 Vdc typ. for 27 V model.	Connect AC input power to the input terminals. This will charge the battery, and will cause the signal to return to a High state after sufficient charging time has elapsed.
	Battery is not connected.	Check connections to the battery.
AC OK signal status is High	Input AC voltage is not available.	Check wiring of AC input voltage to the power supply.
	Power supply is operating in buffering mode.	

# PJU Open Frame Power Supply with Integrated DC-UPS

## PJU-60 W Series / PJU-□V60W□□□

### Others

#### PFC – Norm EN 61000-3-2

##### Line Current Harmonic content



Typically, the input current waveform is not sinusoidal due to the periodic peak charging of the input capacitor. In industrial environments, compliance with EN 61000-3-2 is only necessary under special conditions. Complying to this standard can have some technical drawbacks, such as lower efficiency; and, can also result in higher product cost. Frequently, the user does not profit from compliance to this standard; therefore, it is important to know whether it is mandatory to meet this standard for a specific application.

### Attention

Delta provides all information in the datasheets on an “AS IS” basis and does not offer any kind of warranty through the information for using the product. In the event of any discrepancy between the information in the catalog and datasheets, the datasheets shall prevail (please refer to [www.DeltaPSU.com](http://www.DeltaPSU.com) for the latest datasheets information). Delta shall have no liability of indemnification for any claim or action arising from any error for the provided information in the datasheets. Customer shall take its responsibility for evaluation of using the product before placing an order with Delta.

Delta reserves the right to make changes to the information described in the datasheets without notice.

### Manufacturer and Authorized Representatives Information

#### Manufacturer

##### Thailand

Delta Electronics (Thailand) PCL.  
909 Pattana 1 Rd., Muang, Samutprakarn, 10280 Thailand

##### Taiwan

Delta Electronics, Inc.  
3 Tungyuan Road, Chungli Industrial Zone, Taoyuan County  
32063, Taiwan

#### Authorized Representatives

##### The Netherlands

Delta Greentech (Netherlands) B.V.  
Zandsteen 15, 2132 MZ Hoofddorp, The Netherlands

##### United Kingdom

Delta Electronics Europe Limited  
1 Redwood Court, Peel Park Campus,  
East Kilbride, Glasgow, G74 5PF, United Kingdom