

CliQ II DC-UPS Module

24V 40A / DRU-24V40ABN



Highlights & Features

- Full corrosion resistant Aluminium chassis
- Suitable for 24V system up to 40A
- Built-in diagnostic monitoring for DC OK, Discharge and Battery Fail by relay contacts
- LED indicator for DC OK, Battery Fail, DC Input, Battery Reverse Polarity and Battery Discharge
- High MTBF > 500,000 hrs as per Telcordia SR-332
- Wide operation temperature range from -20°C to +60°C
- Conformal coating on PCBA to protect against chemical and dust pollutants

Safety Standards



CB Certified for worldwide use

Model Number: DRU-24V40ABN
Unit Weight: 0.60 kg (1.32 lb)
Dimensions (L x W x D): 121 x 50 x 117.3 mm
 (4.76 x 1.97 x 4.62 inch)

General Description

The DRU-24V40ABN CliQ II DC-UPS module is designed to support 24V system with up to 40A output and back up time of 4.5 minutes for 15AH battery capacity. It offers a wide input voltage from 24-28V and a wide operating temperature range from -20°C to +60°C. This product comes with potential free contacts for battery management signals and LED indicator for battery status. The rugged compact aluminium case is shock and vibration resistant according to IEC 60068-2.

Model Information

CliQ II DC-UPS Module

Model Number	Input Voltage Range	Rated Output Voltage	Rated Output Current
DRU-24V40ABN	24-28Vdc	24Vdc typ. (Depends on V_{in})	40.0A Max

Model Numbering

DR	U –	24V	40A	B	N
DIN Rail	DC-UPS Module	Output Voltage	Output Current	CliQ II Series	N - Metal Case, without Class I, Div 2

1 | All parameters are specified at 25°C ambient and AC input unless otherwise indicated.
 (November 2018, Rev. 03)



CliQ II DC-UPS Module

24V 40A / DRU-24V40ABN

Specifications

Input Ratings / Characteristics

Nominal Input Voltage	24Vdc
Input Voltage Range	24-28Vdc
Input Current	Charging Mode 2A ± 1A
Charging Time*	< 3hr ± 1hr for battery 24V/15AH
Efficiency	Charging Mode > 70.0%
	Buffering Mode > 99.0%

*Charging time depends on the last state of discharge w.r.t. buffering time and load current.

Output Ratings / Characteristics

Output Voltage Range	23-28Vdc
Output Current	40.0A Max
Output Power	960W Max (24V, 40A)
Voltage Drop Between Input and Output	Charging Mode 0V between DC input to load
	Buffering Mode 0.1V between battery to load @ 40A load

Battery Input / Output Characteristics

Nominal Battery Voltage	24Vdc, SLA Sealed lead acid battery 2 x 12Vdc, SLA Sealed lead acid battery
Battery Voltage Range	23-28Vdc (continuously operating) 30Vdc Max (the maximum voltage that will not cause damage to the unit) 14Vdc Min (the voltage level of battery to enable "BAT Fail" function)
Battery Capacity	7.5AH/ 12AH/ 15AH
Battery Fuse	Auto 50A / 80V, FK3 (Littelfuse) or similar in the battery path. The battery fuse protects the wires between the battery and the unit.
Battery Charging Mode	CC-mode (constant current) at 2A
End-of-Charge Voltage	The unit always charge with fix input voltage value

CliQ II DC-UPS Module

24V 40A / DRU-24V40ABN

Buffering Time

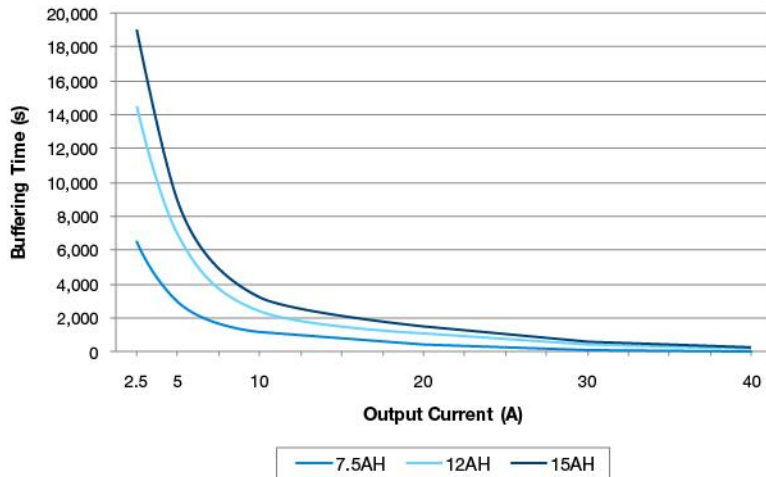

Output Current	Buffering Time		
	7.5AH	12AH	15AH
2.5A	6,500s	14,500s	19,000s
5A	3,000s	7,000s	9,000s
10A	1,200s	2,400s	3,200s
20A	400s	1,100s	1,500s
30A	120s	450s	600s
40A	25s	200s	280s

Fig. 1 Buffering Time VS. Output Current

Mechanical

Case Cover / Chassis		Aluminium
Dimensions (L x W x D)		121 x 50 x 117.3 mm (4.76 x 1.97 x 4.62 inch)
Unit Weight		0.60 kg (1.32 lb)
Cooling System		Convection
Terminal	Input / Output	4 Pins (Rated 600V/60A)
	Signal	6 Pins (Rated 300V/27A)
Wire	Input / Output	AWG 12-6 (Load: 0-20A) AWG 8-6 (Load 20-40A)
	Signal	AWG 24-12
Mounting Rail		Standard TS35 DIN Rail in accordance with EN 60715
Noise (1 Meter from power supply)		Sound Pressure Level (SPL) < 40dBA

CliQ II DC-UPS Module

24V 40A / DRU-24V40ABN

Environment

Surrounding Air Temperature	Operating	-20°C to +60°C (full power)
	Storage	-40°C to +85°C
Operating Humidity	5 to 95% RH (Non-Condensing)	
Operating Altitude	0 to 3,000 Meters (9,800 ft)	
Shock Test (Non-Operating)	IEC 60068-2-27, 30G (300m/S ²) for a duration of 18ms, 1 time per direction, 2 times in total	
Vibration (Non-Operating)	IEC 60068-2-6, 10Hz to 500Hz @ 30m/S ² (3G peak); 60 min per axis for all X, Y, Z direction	
Pollution Degree	2	

Protections

Overload / Overcurrent	42-52A, Latch-off Mode
Over Temperature	< 90°C Surrounding Air Temperature inside the unit, Latch-off Mode
Short Circuit (at system)	Shutdown, Latch-off Mode
Input Polarity Protection*	Yes (DC OK = open contact, LED Status = Orange)
Battery Polarity Protection*	Yes (DC OK = open contact, LED Status = Orange)
Wrong Battery Voltage Protection	Yes, 30Vdc Max (the maximum voltage that will not cause damage to the unit)
Deep Discharge Protection	Yes (23V ± 0.5V)**
Degree of Protection	IP20
Protection Against Shock	Class III

*If the orange status LED is on, this indicates a failure in the installation. In this case, do not turn on power supply while the battery is connected. Danger of explosion!

** The unit will stop operating when the battery voltage detected is less than 23V ± 0.5V

Reliability Data

MTBF	> 500,000 hrs. as per Telcordia SR-332
------	--

Safety Standards / Directives

Electrical Equipment in Power Installations	EN 50178 / IEC 62103	
Electrical Safety	SIQ to EN 60950-1, UL/cUL recognized to UL 60950-1 and CSA C22.2 No. 60950-1, CB scheme to IEC 60950-1	
Industrial Control Equipment	UL/cUL listed to UL 508 and CSA C22.2 No. 107.1-01, CSA to CSA C22.2 No. 107.1-01 (File No. 181564)	
CE	In conformance with EMC Directive 2014/30/EU and Low Voltage Directive 2014/35/EU	
Material and Parts	RoHS Directive 2011/65/EU Compliant	
Galvanic Isolation	Power Port to Housing	1.0KVac
	Signal Port to Housing	1.0KVac
	Power Port to Signal Port	1.0KVac

CliQ II DC-UPS Module

24V 40A / DRU-24V40ABN

EMC

Emissions (CE & RE)		CISPR 32, EN 55032, EN 55011, FCC Title 47: Class B
Component Power Supply for General Use		EN 61204-3
Immunity to		EN 55024, EN 61000-6-2
Electrostatic Discharge	IEC 61000-4-2	Level 4 Criteria A ¹⁾ Air Discharge: 15kV Contact Discharge: 8kV
Radiated Field	IEC 61000-4-3	Level 3 Criteria A ¹⁾ 80MHz-1GHz, 10V/M, 80% modulation (1KHz) 1.4GHz-2GHz, 3V/M, 80% modulation (1KHz) 2GHz-2.7GHz, 1V/M, 80% modulation (1KHz)
Electrical Fast Transient / Burst	IEC 61000-4-4	Level 3 Criteria A ¹⁾ 2kV (Input power ports)
Surge	IEC 61000-4-5	Level 3 Criteria A ¹⁾ 0.5kV (Input power ports)
Conducted	IEC 61000-4-6	Level 3 Criteria A ¹⁾ 150kHz-80MHz, 10Vrms
Power Frequency Magnetic Fields	IEC 61000-4-8	Criteria A ¹⁾ 10A/Meter

1) Criteria A: Normal performance within the specification limits

Block Diagram

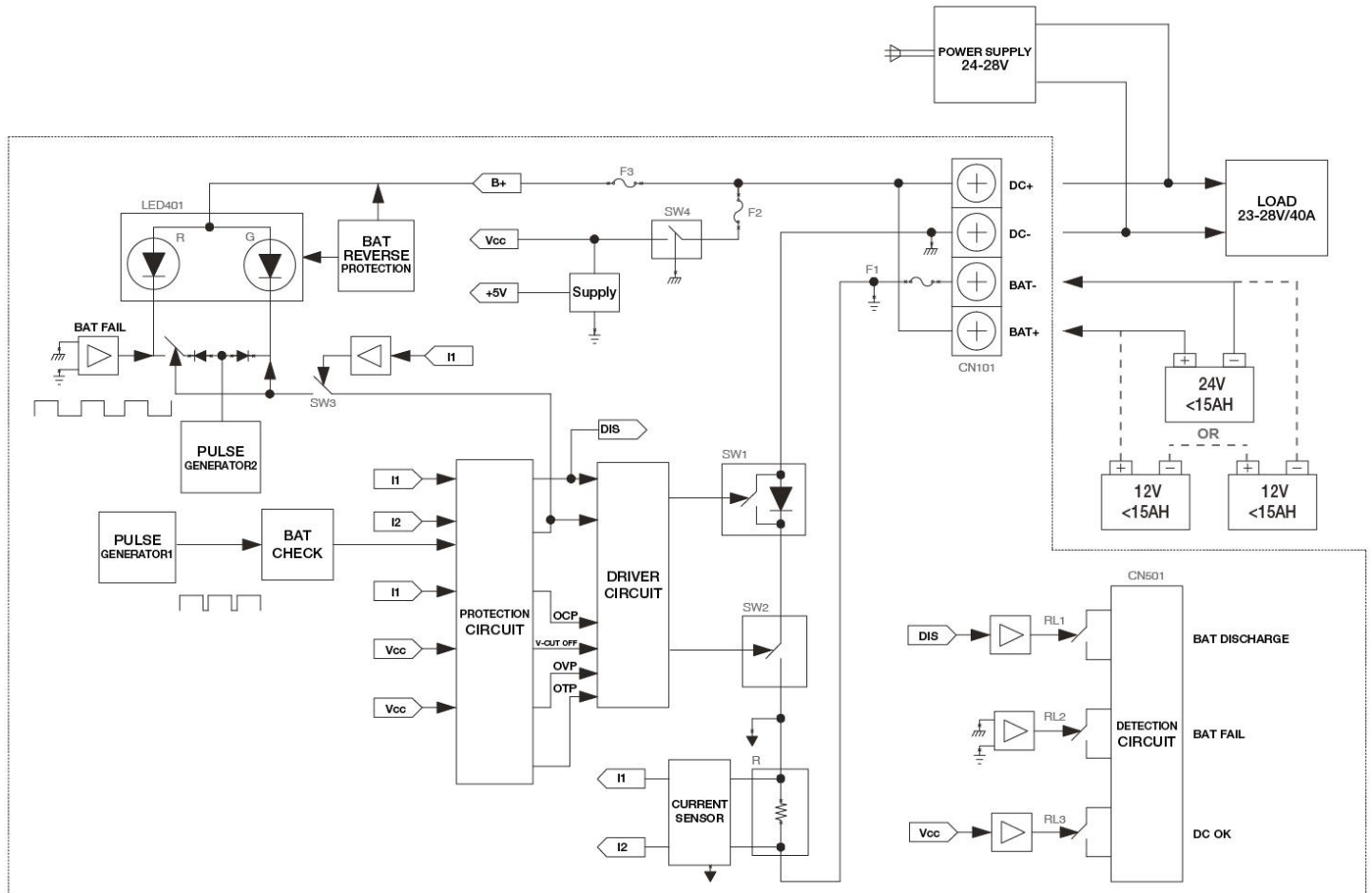

CliQ II DC-UPS Module

24V 40A / DRU-24V40ABN

Device Description

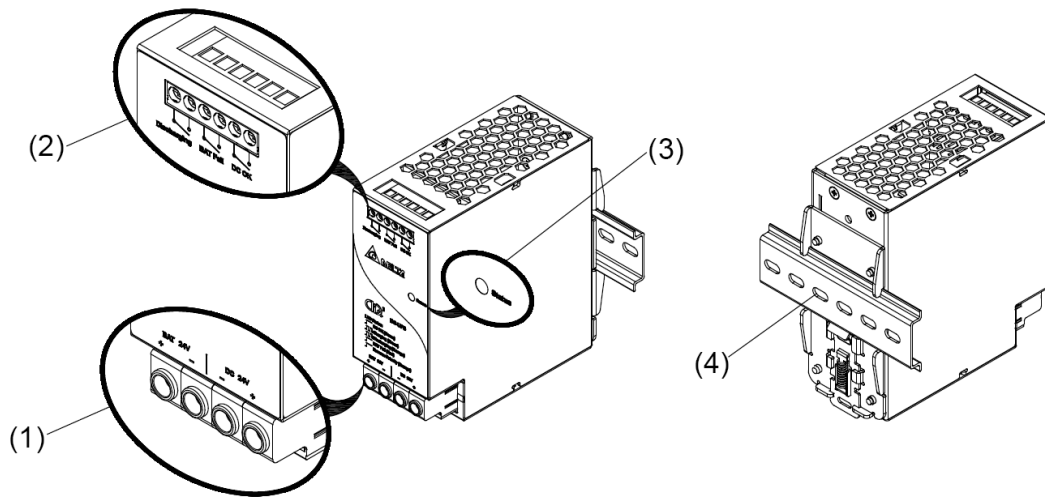

- 1) Input / Output terminal block connector
- 2) Signal terminal block connector
- 3) LED display status
- 4) Universal mounting rail system

Dimensions

L x W x D: 121 x 50 x 117.3 mm (4.76 x 1.97 x 4.62 inch)

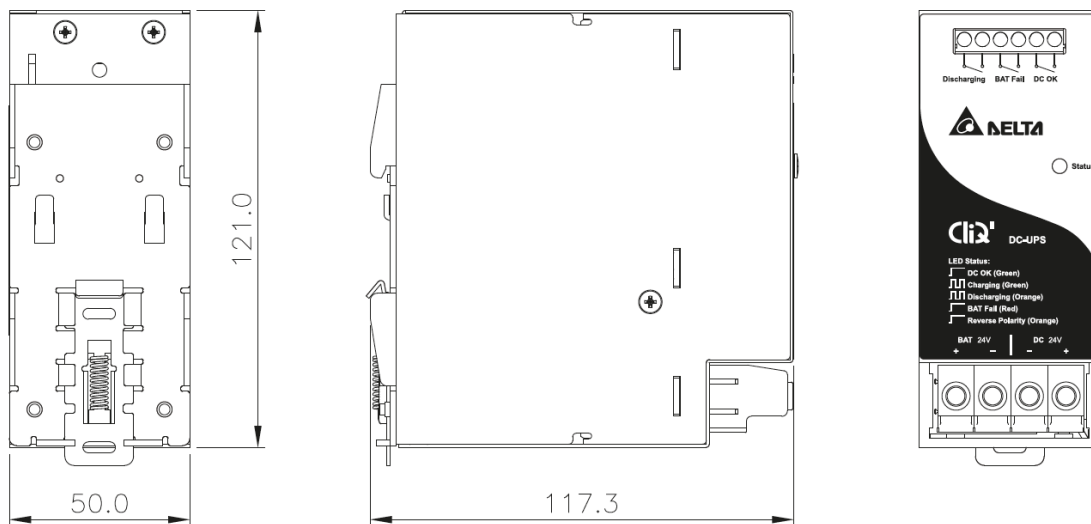

CliQ II DC-UPS Module

24V 40A / DRU-24V40ABN

Engineering Data

Output Load De-rating VS Surrounding Air Temperature

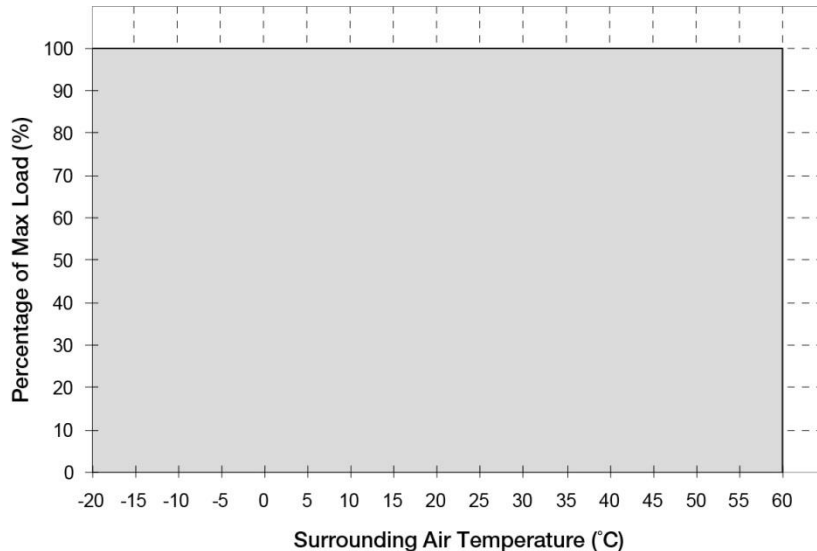

Fig. 2 No power de-rating across the entire operating temperature range (-20°C to +60°C)

Note

1. The unit may degrade, or be damaged, when it is continuously used outside the shaded region, refer to the graph shown in Fig. 2.
2. When the DC-UPS module is used with power supply of different ratings, user must follow power supply derating curve or whichever is lower.
3. In order for the device to function in the manner intended, it is also necessary to keep a safety distance of 50mm above and below the device as well as a lateral distance of 20mm (for Vertical Mounting) or 50mm (for Horizontal Mounting) with adjacent units while the device is in operation.
4. Depending on the surrounding air temperature and output load delivered by the power supply, the device can be very hot!
5. If the device has to be mounted in any other orientation, please do not hesitate to contact info@deltapsu.com for more details.

Assembly & Installation

The unit can be mounted on 35mm DIN rails in accordance with EN 60715. For Vertical Mounting, the device should be installed with Input / Output terminal block on the bottom. For Horizontal Mounting, the device should be installed with Input / Output terminal block on the left side.

Each device is delivered ready to install.

Mounting

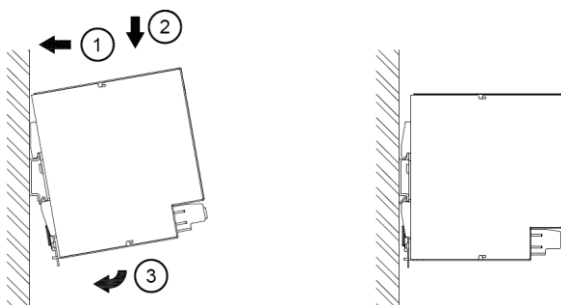

Fig. 3.1 Mounting

Snap on the DIN rail as shown in Fig. 3.1:

1. Tilt the unit upwards and insert it onto the DIN rail.
2. Push downwards until stopped.
3. Press against the bottom front side for locking.
4. Shake the unit slightly to ensure that it is secured.

Dismounting

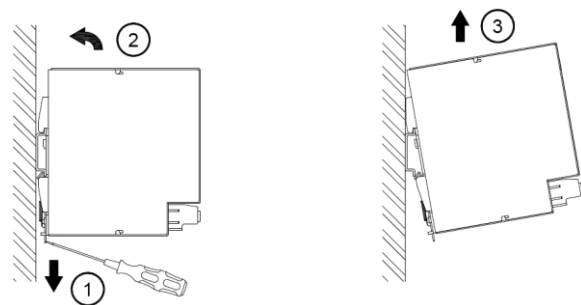

Fig. 3.2 Dismounting

To uninstall, pull or slide down the latch with screw driver as shown in Fig. 3.2. Then slide the unit in the opposite direction, release the latch and pull out the unit from the rail.

CliQ II DC-UPS Module

24V 40A / DRU-24V40ABN

Safety Instructions

■ Vertical Mounting

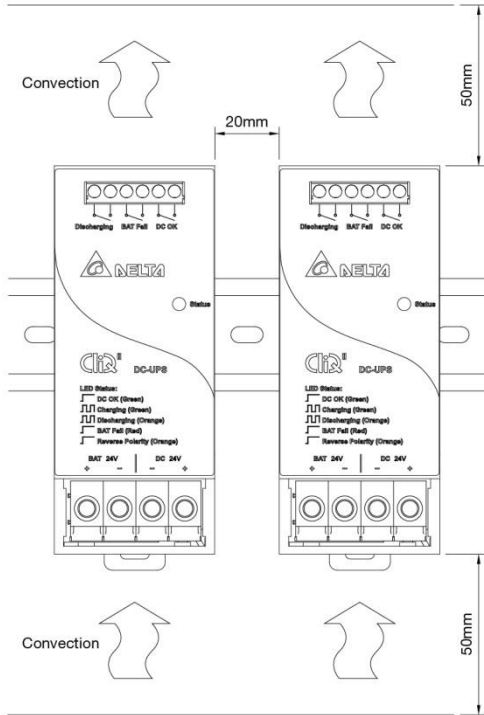

■ Horizontal Mounting

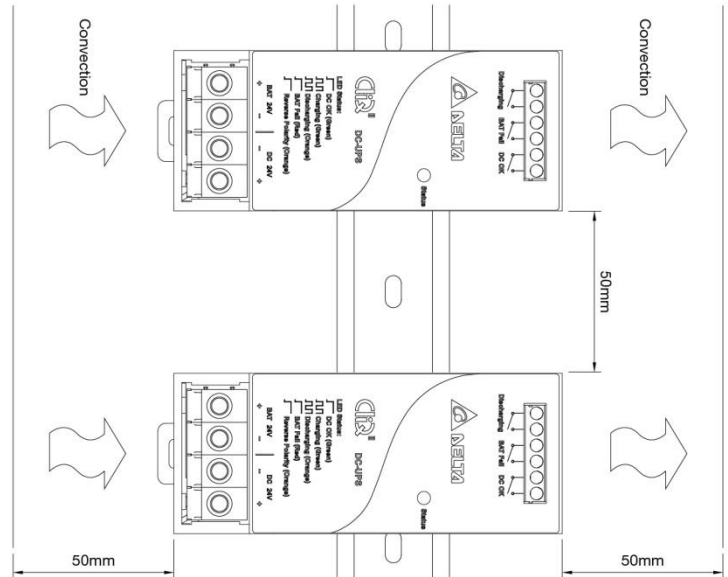

- When replacing batteries, only use the same type of batteries listed under the “Battery Input / Output Characteristics” section on Page 2.
- Proper disposal of batteries is required. Refer to the relevant local codes for disposal requirements.
- ALWAYS switch mains of input power OFF before connecting and disconnecting the input voltage to the unit. If mains are not turned OFF, there is risk of explosion / severe damage.
- If the orange status LED is on, this indicates a failure in the installation. In this case, do not turn on power supply while the battery is connected. Danger of explosion!
- **To guarantee sufficient convection cooling, keep a distance of 50mm above and below the device as well as a lateral distance of 20mm (for Vertical Mounting) or 50mm (for Horizontal Mounting) to other units.**
- Note that the enclosure of the device can become very hot depending on the surrounding air temperature and load of the power supply. Risk of burns!
- The main power must be turned off before connecting or disconnecting wires to the terminals!
- DO NOT insert any objects into the unit.
- Hazardous voltages may be present for up to 5 minutes after the input mains voltage is disconnected. Do not touch the unit during this time.
- The unit is a built-in unit and must be installed in a cabinet or room (condensation free environment and indoor location) that is relatively free of conductive contaminants.

CliQ II DC-UPS Module

24V 40A / DRU-24V40ABN

Functions

Relay Contacts Characteristics

Max Relay Contact Rating		24Vdc/Vac, 1.0A
DC BUS OK	Relay Contact	“DC OK” contact is closed when the DC input voltage is within 24-28V ($\pm 10\%$) range or the battery voltage is within 23-28V range
	LED Indicator	Green LED On
Charging	Relay Contact	“DC OK” contact is closed when the unit is in charging mode
	LED Indicator	Green LED Flashing
Battery Discharge*	Relay Contact	“Discharging” contact is closed when the unit is in buffering mode
	LED Indicator	Orange LED Flashing
Battery Fail	Relay Contact	“BAT Fail” contact is closed when the battery fails to function or battery voltage is less than 14V
	LED Indicator	Red LED On
Battery Reverse Polarity	Relay Contact	“DC OK” contact is opened when the battery is in reverse polarity
	LED Indicator	Orange LED On

* With output current 3A to 40A.

Signals Wiring Diagram

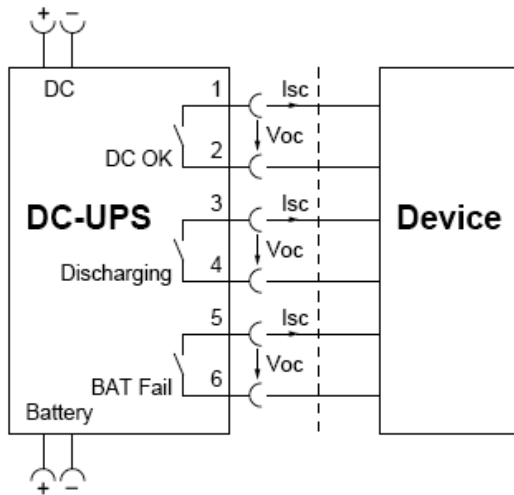

DC-UPS Status	Relay Output Connector			LED Display Status
	Discharging	BAT Fail	DC OK	
Battery Fully Charged	Open	Open	Close	Green LED On
Battery Charging	Open	Open	Close	Green LED Flashing
Battery Discharging* (Buffering Mode)	Close*	Open	Close	Orange LED Flashing
No Battery Connected	Open	Close	Open	Red LED On
Output Shutdown	Open	Open	Open	No Light

*With output current 3A to 40A.

CliQ II DC-UPS Module

24V 40A / DRU-24V40ABN

Charging Mode

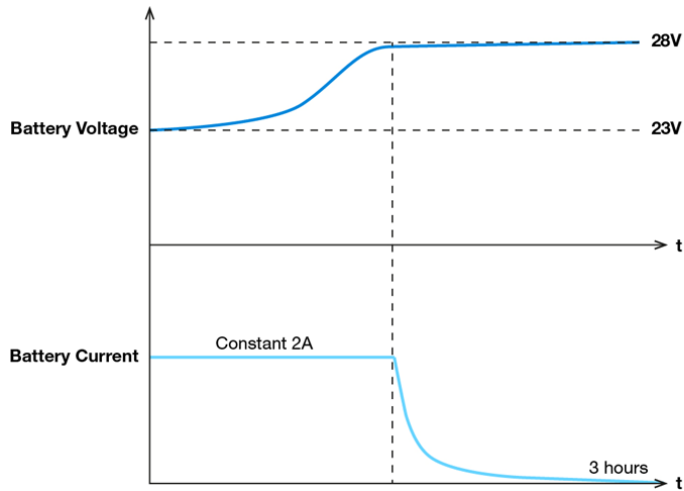

Buffering Mode

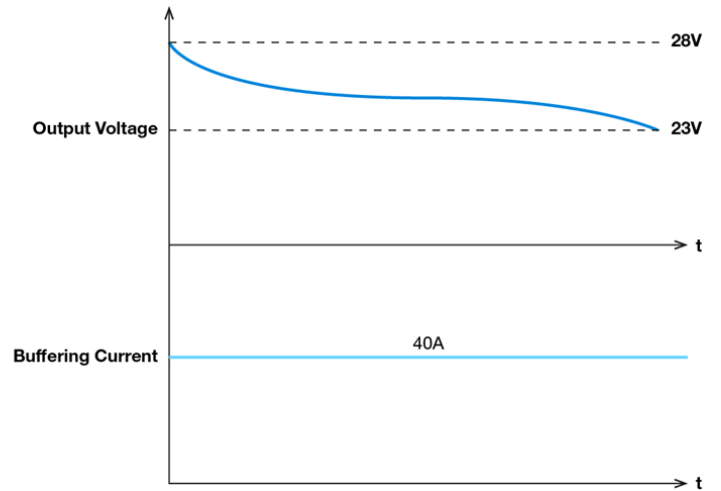

Typical Application Notes

Fig. 4.1 Provide backup power during AC source interruption or failure

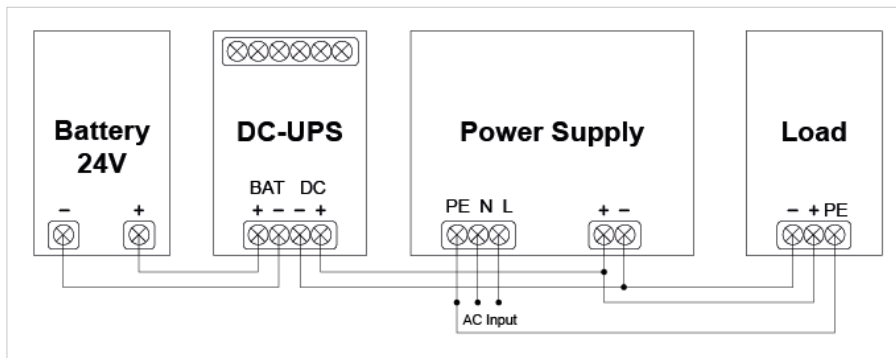
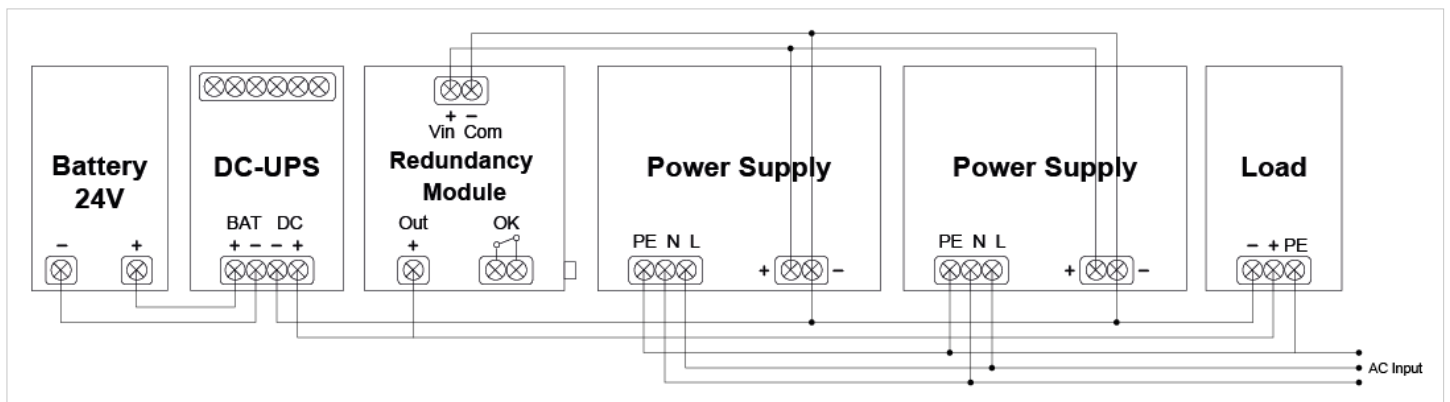

Fig. 4.2 Can be combined with redundancy module (DRR-40A)



CliQ II DC-UPS Module

24V 40A / DRU-24V40ABN

Overload & Overcurrent Protections

When the output current exceeds the maximum specified output current. The DC-UPS module will shut down and protect itself. Normal operation of the module can be resumed upon removal of fault.

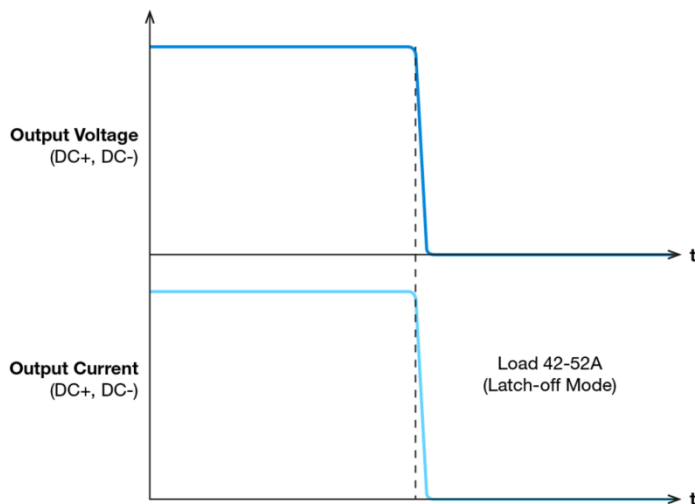

Overvoltage Protection

The DC-UPS module's overvoltage protection will be activated when DC input to the module exceeds the maximum specified input voltage. The unit shall shutdown and return to normal state when the OVP condition is removed.

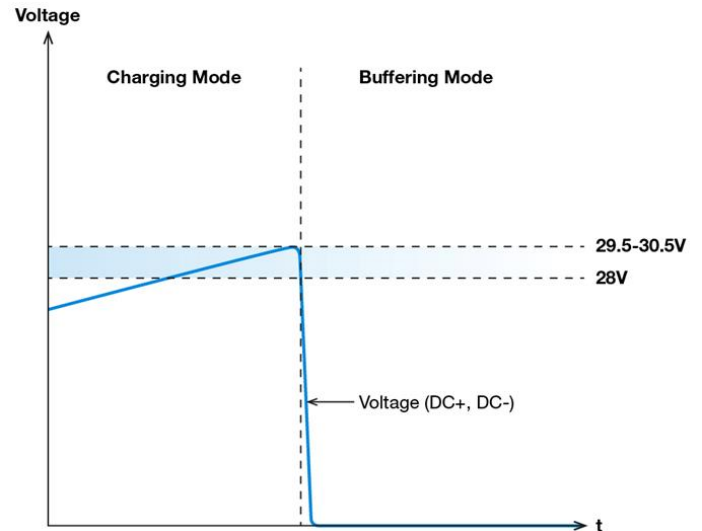

Short Circuit Protection

The module is protected in case of short circuit at customer system, in the event of short circuit the module will shut down and protect itself. Normal operation can be resumed upon removal of fault.

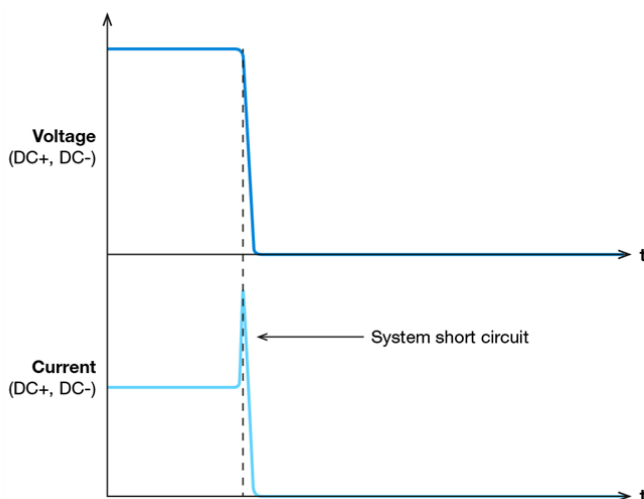

Over Temperature Protection

In the event of a higher operating temperature at 100% load, the power supply will run into OTP when the operating temperature is beyond what is recommended in the de-rating graph. When activated, the output voltage will shut down and remain in off state until the temperature drops to its normal operating temperature as recommended in the de-rating graph.

CliQ II DC-UPS Module

24V 40A / DRU-24V40ABN

Others

Delta RoHS Compliant



Restriction of the usage of hazardous substances

The European directive 2011/65/EU limits the maximum impurity level of homogeneous materials such as lead, mercury, cadmium, chrome, polybrominated flame retardants PBB and PBDE for the use in electrical and electronic equipment. RoHS is the abbreviation for "Restriction of the use of certain hazardous substances in electrical and electronic equipment".

This product conforms to this standard.

Conformal Coating

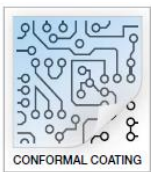

The Protective Coating Technology

Delta Electronics Group has designed the perfect dipping technique which penetrates everywhere including under device, and prevents leakage. The conformal coating dipping can be applied to PCBs or circuit board. The coating preserves the performance of precision electronic primarily by preventing ionizable contaminants such as salt from reaching circuit nodes, where the material slumps around sharp edges. This can be a problem especially in highly conversing atmosphere.

Attention

Delta provides all information in the datasheets on an "AS IS" basis and does not offer any kind of warranty through the information for using the product. In the event of any discrepancy between the information in the catalog and datasheets, the datasheets shall prevail (please refer to www.DeltaPSU.com for the latest datasheets information). Delta shall have no liability of indemnification for any claim or action arising from any error for the provided information in the datasheets. Customer shall take its responsibility for evaluation of using the product before placing an order with Delta.

Delta reserves the right to make changes to the information described in the datasheets without notice.